



USER MANUAL

H400 High Performance Vector Inverter

EXPERT OF INVERTER/VFD

FMZ CHINA

Version: V2. 0

Preface

First of all, thank you for purchasing the high-performance vector inverter developed by our company!

The company's high-performance vector inverter is a general-purpose multi-function inverter that can perform V/F control or vector control on AC asynchronous motors. It can be used to drive textile, paper, wire drawing, machine tools, packaging, food, fans, and water pumps. And various automated production equipment, large starting torque, simple debugging, can achieve 16-speed operation, system closed loop, process control and networking functions.

This manual introduces the configuration functions and usage methods of our company's high-performance vector inverters.

Please use the product after understanding the safety precautions of the product. Before using the inverter for the first time (installation, operation, maintenance, inspection, etc.), and please be sure to read this manual carefully. Equipment configuration manufacturers please send this manual along with the device to the end user for subsequent use and reference.

Notes

- In order to illustrate the details of the product, the illustrations in this manual sometimes show the state of removing the cover or safety cover. When using this product, be sure to install the cover or cover according to the regulations and operate in accordance with the content of the manual.
- The illustrations in this instruction manual are for illustration only and may be different from the products you ordered.
- Due to product upgrades or specification changes, and in order to improve the convenience and accuracy of the manual, the content of this manual will be changed in time.
- If you need to order the instruction manual due to damage or loss, please contact our company's regional agents, or directly contact our company's customer service center.
- If you still have some unclear usage problems during your use, please contact our company's customer service center.

Introduction

The company's new generation of modular high-performance inverters representing the development direction of future inverters. Compared with inverters in the traditional sense, it is not achieved through multiple series of products in terms of meeting customers' different performance and functional requirements (Thereby increasing additional manufacturing, sales, use, and maintenance costs), but based on the reasonable segmentation of customer needs, modular design, through the flexible combination of multiple modules of a single series of products, to create a customized platform.

This manual provides users with relevant precautions and guidance on type selection, installation, parameter setting, on-site debugging, fault diagnosis, and daily maintenance and maintenance. In order to use this series of inverters correctly, please read this manual carefully in advance and keep it properly for later use. Equipment matching customers please send this manual along with the equipment to the end user.

Unpacking and inspection:

When unpacking, please confirm carefully:

- 1) Whether the model of the nameplate of the machine and the rated value of the inverter are consistent with your order. The box contains the machine you ordered, product qualification certificate, user operation manual and warranty.
- 2) Whether the product is damaged during transportation; if there is any omission or damage, please contact our company or your supplier as soon as possible.

First use:

For users who use this product for the first time, please read this manual carefully. If you have any doubts about some functions and performance, please consult our company's technical support personnel for help, which is beneficial to the correct use of this product to improve efficiency.

Due to the continuous improvement of the inverter, the information provided by the company is subject to change without notice.

Directory

Preface	2
Introduction	3
Directory	4
Chapter 1 Safety Information and Precautions	7
1.1 Safety matters	7
1.2 Matters needing attention	10
Chapter 2 Product Information	13
2.1 Model and technical data	13
2.2 Technical specifications	15
2.3 Product appearance drawing, installation hole size	18
2.4 Optional accessories	23
2.5 Daily maintenance and maintenance of the inverter	24
2.6 Warranty instructions for the inverter	26
2.7 Selection guide	26
2.8 Selection guide for brake components	27
Chapter 3 Mechanical and Electrical Installation	30
3.1 Mechanical installation	30
3.2 Electrical installation	32
Chapter 4 Operation and Display	40
4.1 Introduction to Operation and Display Interface	40
4.2 Automatic tuning of motor parameters	42
Chapter 5 Function Parameter Table	44
Brief table of basic function parameters	45
Chapter 6 Failure and Diagnosis	86
6.1 Fault alarm and countermeasures	86
6.2 Common faults and their solutions	90
Chapter 7 Communication Agreement	94
Chapter 8	105
8.1 Constant pressure water supply parameter setting case	106
8.2 Three-line operation	108
8.3 Multi-speed operation	109

Connection with peripheral equipment

Three-phase AC power supply

Please use the power supply within the allowable specifications of the inverter

No-fuse circuit breaker (MCCB) Or leakage circuit breaker

Since the inverter will flow in a large inrush current when the power is turned on, it is necessary to pay attention to the selection of the short-circuit device.

Electromagnetic contactor

To ensure safety, please do not use electromagnetic contactors to start and stop the inverter, as this will reduce the service life of the inverter

AC reactor

Braking unit: Suppress high-order harmonics and improve power factor

Input side noise filter

Inverter

In order to prevent electric shock, the motor and inverter must be well grounded.

Output side noise filter

Motor

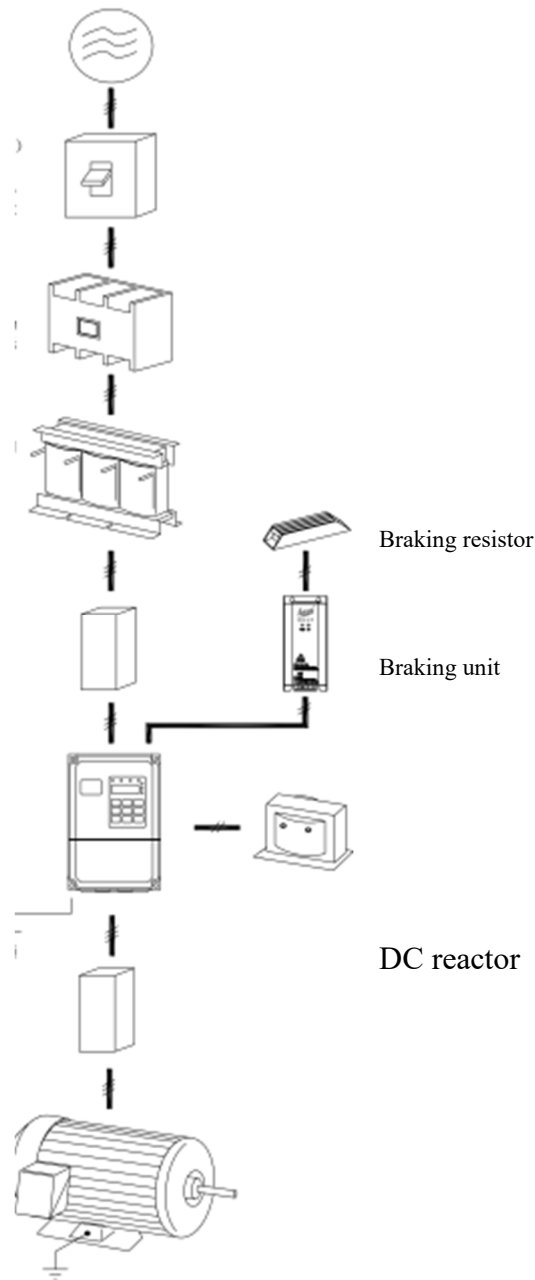

Example of connection with peripheral equipment

- Do not install capacitors or surge suppressors on the output side of the inverter. This will cause the inverter to malfunction or damage the capacitors and surge suppressors.
- The input or output of the inverter (main circuit) contains harmonic components, which may interfere with the communication equipment attached to the inverter. Therefore, install an anti-interference filter to minimize interference.
- For details and options of peripheral equipment, refer to the selection manual of peripheral equipment.

1

Safety information and precautions

Chapter 1

Chapter 1 Safety Information and Precautions

Security definition:

In this manual, safety precautions are divided into the following two categories:



Danger: due to the danger caused by the failure to operate as required, it may cause serious injury or even death;



Note: The danger caused by failure to operate as required may result in moderate injury or minor injury, and equipment damage;

Please read this chapter carefully when installing, debugging and servicing this system, and be sure to follow the safety precautions required by this chapter. Any injury or loss caused by illegal operation has nothing to do with our company.

1.1 Safety matters



1.1.1 Before installation:

	Danger
<ul style="list-style-type: none"> • Please do not install if water in the control system, missing parts, or damaged parts are found when unpacking! • When the packing list does not match the actual name, please do not install 	
	Danger
<ul style="list-style-type: none"> • When transporting, it should be lifted and handled gently, otherwise there is a risk of damage to the equipment! • Do not use damaged drives or inverters with missing parts. There is a risk of injury! • Do not touch the components of the control system with your hands, otherwise there is a danger of static electricity damage! 	



1.1.2 When installing:

	Danger
<ul style="list-style-type: none"> • Please install it on flame-retardant objects such as metal: Keep away from combustible materials. Otherwise, it may cause a fire! • Do not twist the fixing bolts of the equipment components at will, especially the bolts with red marks! 	
	Note
<ul style="list-style-type: none"> • Do not let the wire heads or screws fall into the drive. Otherwise it will cause damage to the drive! • Please install the drive in a place with little vibration and avoid direct sunlight. • When two or more inverters are placed in the same cabinet, please pay attention to the installation position to ensure the heat dissipation effect. 	



1.1.3 When wiring:

 Danger
<ul style="list-style-type: none">• The instructions in this manual must be followed, and the construction should be carried out by professional electrical engineers, otherwise unexpected dangers may occur!
<ul style="list-style-type: none">• There must be a circuit breaker between the inverter and the power supply, otherwise a fire alarm may occur!
<ul style="list-style-type: none">• Please confirm that the power supply is in a zero energy state before wiring, otherwise there is a danger of electric shock!
<ul style="list-style-type: none">• Please perform correct and standardized grounding of the inverter according to the standard, otherwise there is a danger of electric shock!
 Danger
<ul style="list-style-type: none">• Never connect the input power supply to the output terminals (U, V, W) of the inverter. Pay attention to the markings of the wiring terminals and do not connect the wrong wires! Otherwise, the drive may be damaged!
<ul style="list-style-type: none">• Ensure that the wiring meets the EMC requirements and the safety standards of the area. Please refer to the recommendations of the manual for the wire diameters used. Otherwise, accidents may occur!
<ul style="list-style-type: none">• Never connect the braking resistor directly between the (+) and (-) terminals of the DC bus. Otherwise, it may cause a fire!
<ul style="list-style-type: none">• Encoder must use shielded wire, and the shielding layer must ensure reliable single-ended grounding!



1.1.4 Before power-on:

 Note
<ul style="list-style-type: none">• Please confirm whether the voltage level of the input power supply is consistent with the rated voltage level of the inverter: whether the wiring positions on the power input terminals (R, S, T) and output terminals (U, V, W) are correct; and pay attention to check with the drive Whether there is a short circuit in the connected peripheral circuit, and whether the connected circuit is tight, otherwise the driver will be damaged!
<ul style="list-style-type: none">• No voltage test is required for any part of the inverter. The product has been tested before leaving the factory. Otherwise, it may cause an accident!
 Danger
<ul style="list-style-type: none">• The inverter must be covered with the cover before it can be powered on. Otherwise, it may cause electric shock
<ul style="list-style-type: none">• All peripheral accessories must follow the instructions of this manual, and wire correctly according to the circuit connection method provided in this manual. Otherwise, it may cause an accident!

1.1.5 After power-on:

 Danger
<ul style="list-style-type: none">• Do not open the cover after power on. Otherwise, there is a risk of electric shock!
<ul style="list-style-type: none">• Do not touch the drive and peripheral circuits with wet hands. Otherwise, there is a danger of electric shock!
<ul style="list-style-type: none">• Do not touch any input and output terminals of the inverter. Otherwise, there is a danger of electric shock!
<ul style="list-style-type: none">• At the beginning of power-on, the inverter will automatically perform safety inspections on the external strong current circuit. At this time, never touch the U, V, W wiring terminals of the drive or the motor wiring terminals, otherwise there is a danger of electric shock!
 Danger
<ul style="list-style-type: none">• If you need to perform parameter identification, please pay attention to the danger of injury from the rotation of the motor. Otherwise, it may cause an accident!
<ul style="list-style-type: none">• Do not change the factory parameters of the inverter at will. Otherwise, it may cause damage to the equipment!

1.1.6 Running:

 Danger
<ul style="list-style-type: none">• Do not touch the cooling fan and discharge resistor to test the temperature. Otherwise, it may cause burns!
<ul style="list-style-type: none">• Non-professional technicians are not allowed to detect signals during operation. Otherwise, personal injury or equipment damage may occur!
 Note
<ul style="list-style-type: none">• When the inverter is running, avoid anything falling into the equipment. Otherwise, it may cause damage to the equipment!
<ul style="list-style-type: none">• Do not use the contactor on-off method to control the start and stop of the drive. Otherwise, the equipment may be damaged!

1.1.7 During maintenance:

 Danger
<ul style="list-style-type: none">• Do not repair and maintain the equipment with power on. Otherwise, there is a danger of electric shock!
<ul style="list-style-type: none">• Confirm that the drive can only be maintained and repaired when the inverter voltage is lower than AC36V, and the drive should be maintained and repaired two minutes after the power is off. Otherwise, the residual charge on the capacitor will cause injury to people!
<ul style="list-style-type: none">• Personnel without professional training are not allowed to repair and maintain the inverter. Otherwise, personal injury or equipment damage may occur!
<ul style="list-style-type: none">• After replacing the inverter, the parameters must be set, and all pluggable plug-ins must be plugged and unplugged when the power is off!

1.2 Matters needing attention

1.2.1 Motor insulation inspection

When the motor is used for the first time, before reuse after a long period of time, and during regular inspections, the motor insulation should be inspected to prevent damage to the inverter due to the insulation failure of the motor windings. The motor wiring must be separated from the inverter during the insulation inspection. It is recommended to use a 500V voltage type megohmmeter, and ensure that the measured insulation resistance is not less than $5M\Omega$.

1.2.2 Thermal protection of motor

If the selected motor does not match the rated capacity of the inverter, especially when the rated power of the inverter is greater than the rated power of the motor, be sure to adjust the motor protection related parameter values in the inverter or install a thermal relay before the motor to protect the motor.

1.2.3 Operation above power frequency

This inverter can provide an output frequency of 0Hz ~ 300Hz. If the customer needs to operate above 50Hz, please consider the endurance of the mechanical device.

1.2.4 Vibration of mechanical devices

At some output frequencies, the converter may encounter the mechanical resonance point of the load device, which can be avoided by setting the jump frequency parameter in the inverter.

1.2.5 Regarding motorized camera heat and noise

Since the output voltage of the inverter is a PWM wave and contains certain harmonics, the temperature rise, noise and vibration of the motor will slightly increase compared to the power frequency operation.

1.2.6 When there is a pressure-sensitive device or a capacitor to improve the power factor on the output side

The output of the inverter is a PWM wave. If a capacitor for improving the power factor or a varistor for lightning protection is installed on the output side, it is easy to cause the inverter to instantaneous overcurrent or even damage the inverter. Please do not use it.

1.2.7 Switching devices such as contactors used at the input and output terminals of the inverter

If a contactor is installed between the power supply and the input terminal of the inverter, it is not allowed to use this contactor to control the start and stop of the inverter. When the contactor must be used to control the start and stop of the inverter, the interval should not be less than one hour. Frequent charging and discharging can easily reduce the service life of the capacitor in the inverter. If a contactor and other switching devices are installed between the output terminal and the motor, make sure that when the inverter has no output, perform the on-off operation, otherwise the modules in the inverter may be damaged.

1.2.8 Use beyond the rated voltage

It is not suitable to use the company's series inverters outside the allowable working voltage range specified in the manual, which may easily cause damage to the internal components of the inverter. If necessary, please use the corresponding step-up or step-down device for voltage transformation.

1.2.9 Change three-phase input to two-phase input

Do not change the three-phase inverter to two-phase use. Otherwise, it will cause malfunction or damage to the inverter.

1.2.10 Lightning impact protection

This series of inverters are equipped with a lightning overcurrent protection device, which has a certain self-protection ability against induced lightning. Customers should also install protection at the front of the inverter for places with frequent lightning.

1.2.11 Altitude and derating use

In areas where the altitude exceeds 1000m, the heat dissipation effect of the inverter is deteriorated due to thin air, it is necessary to derate and use. In this case, please contact our company for technical consultation.;

1.2.12 Some special usage

If customers need to use methods other than the recommended wiring diagrams provided in this manual, such as common DC bus, please consult our company.

1.2.13 Attention when scrapping the inverter

The electrolytic capacitors of the main circuit and the electrolytic capacitors on the printed circuit board may explode when burned. When the plastic parts are burned, toxic gas will be generated. Please dispose of it as industrial waste.

1.2.14 About the adapted motor

1) The standard adapted motor is a four-pole squirrel-cage asynchronous induction motor. If it is not the above motor, please select an inverter according to the rated current of the motor. If you need to drive a permanent magnet synchronous motor, please consult our company:

2) The cooling fan of the non-inverter motor is coaxially connected with the rotor shaft, and the cooling effect of the fan decreases when the speed is reduced. Therefore, when the motor is overheated, a strong exhaust fan should be installed or replaced with a variable frequency motor!

3) The adaptor has built-in standard parameters of the adapted motor. According to the actual situation, it is necessary to identify the motor parameters or modify the default value to meet the actual value as much as possible, otherwise it will affect the operation efficiency and protection performance;

4) A short circuit in the cable or motor will cause the inverter to alarm or even blow up the machine. Therefore, please perform an insulation short-circuit test on the initially installed motor and cable. This test should also be performed frequently during routine maintenance. Note, do this when testing, be sure to disconnect the inverter from the tested part.

2

Product information

Chapter 2

Chapter 2 Product Information

2.1 Model and technical data

Table 2-1

Model	Input voltage	Power supply capacity (KVA)	Input current (A)	Output current (A)	Adapted motor (kw)
H400-0R7G-S2	Single phase 220V range: -15%~20%	1.5	8.2	4.0	0.75
H400-1R5G-S2		3.0	14.2	7.0	1.5
H400-2R2G-S2		4.0	23.0	9.6	2.2
H400-55RG-T6	Three-phase 690V 50/60Hz	85.0	65.0	63.0	55
H400-75RG-T6		114.0	86.0	85.0	75
H400-90RG-T6		134.0	98.0	95.0	90
H400-110RG-T6		160.0	121.0	118.0	110
H400-132RG-T6		192.0	170.0	150.0	132
H400-160RG-T6		231.0	200.0	175.0	160
H400-185RG-T6		240.0	215.0	195.0	185
H400-200RG-T6		250.0	235.0	215.0	200
H400-220RG-T6		280.0	247.0	245.0	220
H400-250RG-T6		355.0	265.0	260.0	250
H400-280RG-T6		396.0	305.0	299.0	280
H400-315RG-T6		445.0	355.0	330.0	315
H400-355RG-T6		500.0	382.0	374.0	355
H400-400RG-T6		565.0	435.0	410.0	400
H400-450RG-T6		630.0	490.0	465.0	450
H400-500RG-T6	700.0	595.0	550.0	500	
H400-560RG-T6	760.0	605.0	590.0	560	

Table 2-2

Model	Input voltage	power supply capacity (KVA)	Input current (A)	Output current (A)	Adapted motor (kw)
H400-0R7G-T4	Three phase 380V range: -15%~+20%	1.5	3.4	2.1	0.75
H400-1R5G-T4		3.0	5.0	3.8	1.5
H400-2R2G-T4		4.0	5.8	5.1	2.2
H400-3R7G-T4		5.9	10.5	9.0	3.7
H400-5R5G-T4		8.9	14.6	13.0	5.5
H400-7R5G-T4		11.0	20.5	17.0	7.5
H400-11RG-T4		17.0	26.0	25.0	11.0
H400-15RG-T4		21.0	35.0	32.0	15.0
H400-18R5G-T4		24.0	38.5	37.0	18.5
H400-22RG-T4		30.0	46.5	45.0	22.0
H400-30RG-T4		40.0	62.0	60.0	30.0
H400-37RG-T4		57.0	76.0	75.0	37.0
H400-45RG-T4		69.0	92.0	91.0	45.0
H400-55RG-T4		85.0	113.0	112.0	55.0
H400-75RG-T4		114.0	157.0	150.0	75.0
H400-90RG-T4		134.0	180.0	176.0	90.0
H400-110RG-T4		160.0	214.0	210.0	110.0
H400-132RG-T4		192.0	256.0	253.0	132.0
H400-160RG-T4		231.0	307.0	304.0	160.0
H400-185RG-T4		240.0	345.0	340.0	185.0
H400-200RG-T4		250.0	385.0	377.0	200.0
H400-220RG-T4		280.0	430.0	426.0	220.0
H400-250RG-T4		355.0	468.0	465.0	250.0
H400-280RG-T4		396.0	525.0	520.0	280.0
H400-315RG-T4		445.0	590.0	585.0	315.0
H400-355RG-T4		500.0	665.0	650.0	355.0
H400-400RG-T4	565.0	785.0	725.0	400.0	

2.2 Technical specifications

Table 2- 3 Technical Specifications of Inverter

	Item	Specification		
Basic functions	Highest frequency	Vector control: 0 ~500Hz V/F control: 0 ~2000Hz		
	Carrier frequency	0.5kHz ~16kHz The carrier frequency can be automatically adjusted according to the load characteristics		
	Input frequency resolution	Digital setting: 0.01Hz Analog setting: maximum frequency X 0.025%		
	control method	Open loop vector control (SVC) Closed loop vector control (FVC) V/F control		
	Starting torque	Model G: 0.25 Hz/150% (SVC); 0Hz/180% (FVC) Model P: 0.5Hz/100%		
	Speed range	1:100(SVC)	1:1000(FVC)	
	Stable speed accuracy	±0.5%(SVC)	±0.02%(FVC)	
	Torque control accuracy	±5%(FVC)		
	Overload capacity	Model G machine: 150% rated current 60s; 180% rated current 3s. Model P machine: 120% rated current 60s; 150% rated current 3s		
	Torque boost	Automatic torque boost: manual torque boost 0.1%-30.0%		
	V/F curve	Three methods: straight type; multi-point type; Nth power type V/F curve(1.2 power, 1.4 power, 1.6 power, 1.8 power, 2 power)		
	V/F separation	2 ways: full separation, semi-separation		
	Acceleration and deceleration curve	Linear or S-curve acceleration and deceleration mode. Four kinds of acceleration and deceleration time, the range of acceleration and deceleration time is 0.0-6500.0s		
	DC braking	DC braking frequency: 0.00Hz~maximum frequency Braking time: 0.0s-36.0s Braking current value : 0.0%~100.0%		
	Jog control	Jog frequency range: 0.00Hz~50Hz. Jog acceleration and deceleration time :0.0~6500.0s		
	Simple PLC, multi-speed operation	Realize up to 16-segment speed operation through built-in PLC or control terminal		
Built-in PID	It is convenient to realize the process control closed-loop control system			

	Automatic voltage adjustment (AVR)	When the grid voltage changes, it can automatically keep the output voltage constant
	Overvoltage and overcurrent stall speed control	Automatically limit the current and voltage during operation to prevent frequent over-current and over-voltage trips
	Fast current limiting function	Minimize over-current faults and protect the inverter from normal operation
	Torque limit and control	The "shovel" feature automatically limits the torque during operation to prevent frequent over-current trips; closed-loop vector mode can realize torque control
Personalization function	Outstanding performance	Realize asynchronous motor and synchronous motor control with high-performance current vector control technology
	Instantaneous stop non-stop	In case of instantaneous power failure, the load feedback energy is used to compensate the voltage drop and maintain the inverter to continue running in a short period of time
	Fast current limit	Avoid frequent over-current faults of the transformer
	Virtual IO	Five groups of virtual DI/DO. Simple logic control can be realized
	The timing control	Timing control function: set time range 0.0Min~6500.0Min
	Multi-motor switching	Four sets of motor parameters, which can realize switching control of four motors
	Multithreaded bus support	Support four field buses : RS-485, Profibus-DP, CANlink, CANopen
	Motor overheat protection	Optional IO expansion card 1, analog input AI3 can accept motor temperature sensor input (PT100, PT1000)
	Multi-encoder support	Support differential, open collector, UVW, resolver, sine and cosine encoders
	User programmable	Optional user programmable card. Secondary development can be realized, and the programming mode is compatible with Inovance's PLC
	Powerful background software	Support inverter parameter operation and virtual oscilloscope function. Graphical monitoring of the internal state of the inverter can be realized through a virtual oscilloscope
Run	Command source	Operation panel setting, control terminal setting, serial communication port setting. Can be switched in many ways
	Frequency source	10 kinds of frequency sources: digital setting, analog voltage setting, analog current setting, pulse setting, serial port setting. Can be switched in a variety of ways

	Auxiliary frequency source	10 kinds of auxiliary frequency sources. It can flexibly realize auxiliary frequency fine-tuning and frequency synthesis
	Input terminal	standard: 6 digital input terminals, one of which supports high-speed pulse input up to 100kHz 2 analog input terminals. 1 only supports 0-10V voltage input, 1 support 0-10V voltage input or 4-20mA current input Expansion capacity: 5 digital input terminals 1 analog input terminal, support -10~10V voltage input, And support PT100\PT1000
	Output terminal	standard: 1 high-speed pulse output terminal (open collector type is optional) • Support 0~100kHz square wave signal output 1 digital output terminal 1 relay output terminal 1 analog output terminal, support 0-20mA current output or 0-10V voltage output Expansion capacity: 1 digital output terminal 1 relay output terminal 2 analog output terminals, support 0-20mA current output or 0-10V voltage output
Ambient	Use place	Indoors, free from direct sunlight, free of dust、corrosive gas、flammable gas、oil mist、water vapor、dripping water or salt, etc.
	Altitude	Less than 1000m
	Ambient temperature	-10℃ ~ +40℃ (Ambient temperature: 40℃ ~50℃. Please use with derating)
	humidity	Less than 95%RH. No condensation
	vibration	Less than 5.9m/s ² (0.6g)
	storage temperature	-20℃ ~ +60℃

2.3 Product appearance drawing, installation hole size

2.3.1 Product appearance figure 2

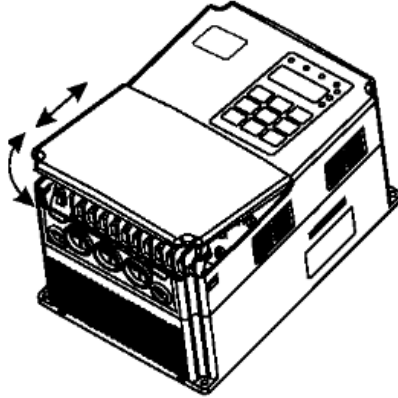

Figure 2-1 Schematic diagram of removal and installation of the plastic cover

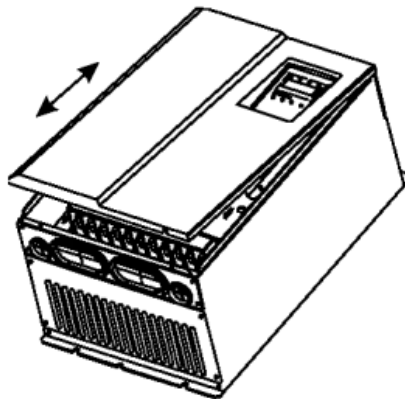

Figure 2-2 Schematic diagram of removal and installation of the sheet metal cover

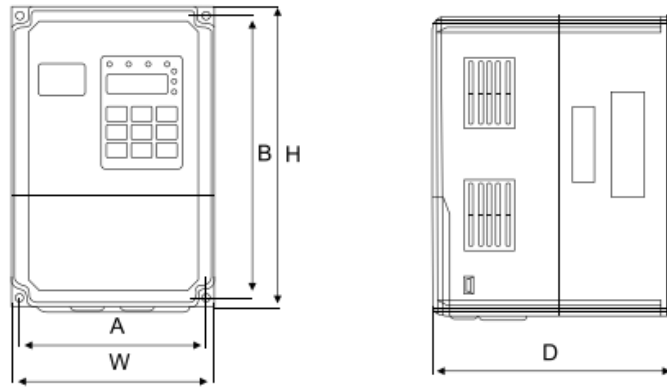

Figure 2-3 Dimensions of 22kw and below plastic models

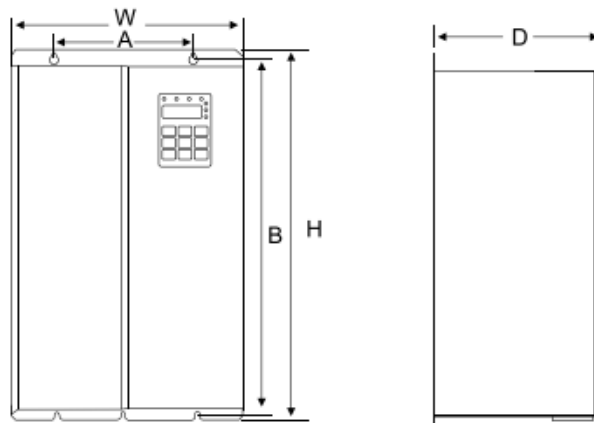

Figure 2-4 Dimensions of 30kw~400kw

2.5.3 Dimensions of external keyboard

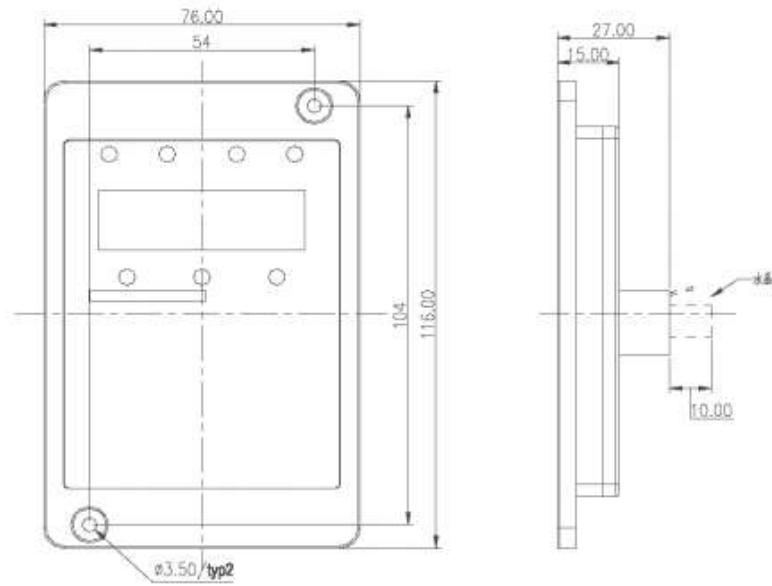

Figure 2-6 Dimensions of external keyboard

Installation opening size of external keyboard:

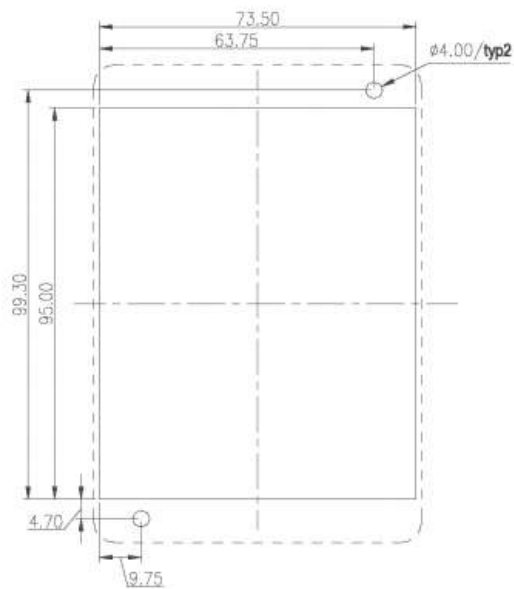

Figure 2-7 The installation hole size of the external keyboard

2.3.2 Appearance and installation hole size:

Table 2-4 Appearance and installation hole size

Power (kW)	A(mm)	B(mm)	H(mm)	W(mm)	D(mm)	Mounting Hole (mm)	Remarks
	Installation size		Dimensions				
1.5-4	113	172	186	125	164	5	
5.5-11	148	236	248	160	183	5	
11-22	190	305	322	208	192	6	
30-37	235	447	463	285	228	6.5	
45-75	260	580	600	385	265	7.0	
90-132	343	678	700	473	307	9.0	
160-200	449	903	930	579	380	12.5	
220-280	420	1030	1060	650	377	12.5	
315-400	520	1300	1360	800	388	12.5	

Note: Due to product upgrades, subject to change size, please prevail in kind.

2.3.3 Dimension drawing of external DC reactor

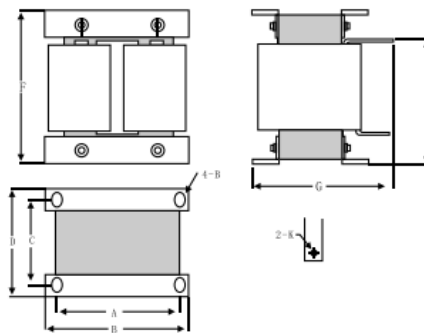

Figure 2-8 Schematic diagram of external reactor size

Table 2-5 Applicable inverter models

Applicable inverter model	A	B	C	D	E	F	G	Fixed hole	Copper bar connection aperture	Reactor model
75kw(G), 90kw (P/G)	160	190	125	161	192	255	195	10*15	Ø12	DCL-0200
110kw(P/G), 132kw (P)	160	190	125	161	192	255	195	10*15	Ø12	DCL-0250
132kw (G), 160 (P/G)	160	190	125	161	192	255	195	10*15	Ø12	DCL-0360
200kw(P/G), 220KW(P/G), 250(P)	190	230	93	128	250	325	200	13*18	Ø15	DCL-0600
250kw(G), 280kw(P/G), 315kw(P)	190	230	93	128	250	325	200	13*18	Ø15	DCL-0700
315kw(G), 355kw (P/G) , 400kw(P/G) 450kw(P)	224	250	135	165	260	335	235	12*20	Ø14	DCL-1000

Note: Special requirements can be customized non-standard

Installation method of external DC reactor:

Inverters with a power above 75kW, all use standard external DC reactors, and are shipped with a separate wooden box when shipped. The user needs to connect the inverter main circuit terminal P1 and (+) directly during installation. Remove the short circuit copper bar of the, and then connect the DC reactor between P1 and (+). The connection between the reactor terminal and the inverter terminal P1 and (+) has no polarity. After installing the DC reactor, P1 the short circuit copper bar between and (+) is no longer used.

2.4 Optional accessories

For the following options, please note when ordering.

Table 2-6 Inverter options

Name	Model	Function	Remarks
Built-in braking unit	After the product model With "B"	Single-phase from 0.4kW-2.2kW, three-phase 0.75kW-15kW built-in brake unit is standard configuration	18.5kW-30kW built-in brake unit optional
External brake unit	VFDBU	External brake unit above 37kW	Use multiple units in parallel for more than 75kw
Energy feedback unit	VFD FB	Energy-saving products that feedback the electric energy in the frequency converter to the AC grid	
Multi-pump water supply control card	VFDWS	A constant pressure water supply system that can realize multi-pump water supply control, a variety of water supply modes can be selected, with sleep function and fire control function.	Built-in clock
I/O expansion card	VFDIO	Five digital inputs, one analog voltage input; one relay output, one digital output, and one analog output can be added.	
MODBUS communication card	VFDMBS	RS 485 communication interface, RS232 communication interface	RJ45 and terminal interface compatible
PROFIBUS-DP bus card	VFD PFS	PROFIBUS-DP bus interface	
DeviceNet bus card	VFD DCT	DeviceNet bus interface	
CANopen bus card	VFDAN	CANopen bus interface	
Ordinary PG card 1	VFD PG	Rotary encoder interface card	Adapt to 15V power supply, push-pull or open collector output encoder
Universal PG card 2	VFD PGD	Rotary encoder interface card with frequency division output	
Long line drive PG	VFD PG3	Suitable for differential encoder	Used in closed-loop control of synchronous motors and induction motors
External LED operation panel	VFDKE	External LED display and operation keyboard	VFD series universal RJ45 interface

External LCD operation panel	VFDKC	External LCD display and operation keyboard	RJ45 interface
Parameter copy unit	VFDPC	Parameter copy	VFD series universal RJ45 interface
EPS mains synchronization card	VFDEPS	EPS mains synchronization	The inverter output voltage is synchronized with the grid voltage
Extension cable	VFDCAB	Standard 8-core network cable, can be connected with VFDKE, VFDKC, VFDPC	Standard configuration 3m
Rectifier unit	VFDRU	Use when the frequency converter shares the bus, with energy-saving function	
Speed tracking card	VFDSTC1	When the inverter stops driving the motor and the motor is in a stopped state, the speed and direction of rotation of the motor can be obtained through the combination of this hardware circuit and software, so as to better control the motor	Add three output cables from U, V, W to the input of the speed tracking card

2.5 Daily maintenance and maintenance of the inverter

2.5.1 Daily maintenance

Due to the influence of environmental temperature, humidity, dust and vibration, the internal components of the inverter will age, leading to potential failures of the inverter or reducing the service life of the inverter. Therefore, it is necessary to implement daily and regular maintenance and maintenance of the inverter.

Daily inspection items:

- 1) Whether the sound changes abnormally during the operation of the motor
- 2) Whether vibration occurs during the operation of the motor
- 3) Whether the inverter installation environment has changed
- 4) Whether the cooling fan of the inverter works normally
- 5) Whether the inverter is overheated.

Daily cleaning:

Keep the inverter clean at all times.

Effectively remove dust on the surface of the inverter to prevent dust from entering the inside of the inverter, especially metal dust. Effectively remove oil stains on the cooling fan of the inverter.

2.5.2 Periodic inspection

Periodically check on the places where it is difficult to check.

Regular inspection items:

- 1) Check the air duct, and regular cleaning
- 2) Check whether the screws are loose
- 3) Check that the inverter is corroded
- 4) Check whether there are arc traces on the wiring terminals
- 5) Main circuit insulation test

Reminder: When measuring the insulation resistance with a megger (please use a DC 500V megger), disconnect the main circuit line from the inverter. Do not use an insulation resistance meter to test the insulation of the control circuit. It is not necessary to carry out a high-voltage test (it has been done before leaving the factory).

2.5.3 Replacement of vulnerable parts of the inverter

The vulnerable parts of the frequency converter are mainly cooling fans and electrolytic capacitors for filtering. Their life is closely related to the environment and maintenance conditions. The general life time is:

Device name	Life time
Fan	2~3 years
Electrolytic capacitor	4~5 years

The user can determine the replacement period according to the operating time.

1) Cooling fan

Possible reasons for damage: bearing wear, blade aging.

Judgment criteria: Whether there are cracks in the fan blades, etc., and whether there are abnormal vibrations when starting the sound.

2) Filter electrolytic capacitor

Possible reasons for damage: poor input power quality, high ambient temperature, frequent load jumps, and electrolyte aging.

Judgment criteria: Whether there is liquid leakage, whether the safety valve has protruded, the measurement of electrostatic capacitance, and the measurement of insulation resistance.

2.5.4 Storage of the frequency converter

After users purchase the inverter, the temporary and long-term storage must note the following:

- 1) When storing, try to put it in the company's packaging box according to the original packaging.
- 2) Long-term storage will cause the deterioration of the electrolytic capacitor. It must be energized once within 2 years for at least 5 hours. The input voltage must be slowly increased to the rated value with a voltage regulator.

2.6 Warranty instructions for the inverter

The free warranty only refers to the inverter itself.

- 1) Under normal conditions of use, in the event of failure or damage, our company is responsible for an 18-month warranty (from the date of manufacture and delivery, subject to the bar code on the fuselage), and a reasonable maintenance fee will be charged for more than 18 months;
- 2) Within 18 months, if the following situations occur, a certain maintenance fee shall be charged;
 - a) The damage to the machine caused by the user not following the provisions in the manual;
 - b) Damage caused by fire, flood, abnormal voltage, etc.;
 - c) Damage caused when the inverter is used for abnormal functions;

Relevant service fees are calculated in accordance with the manufacturer's unified standards, and if there is a contract, the contract shall prevail.

2.7 Selection guide

Three control methods are available: ordinary V/F, SVC, VC.

When selecting a frequency converter, you must first clarify the system's technical requirements for frequency conversion speed regulation, the application of the frequency converter and the specific conditions of the load characteristics, and comprehensively consider factors such as the adapted motor, output voltage, and rated output current, and then choose to meet the required model and determine the operation mode.

The basic principle is: The rated load current of the motor cannot exceed the rated current of the inverter. In general, select the motor capacity specified in the manual, and pay attention to comparing the rated current of the motor and the inverter. The overload capacity of the inverter is important for starting and braking. The driving process is meaningful. Any short-term overload during operation will cause the load speed to change. If the speed accuracy requirements are relatively high, please consider zooming in to a level.

Types of fans and pumps: The requirements for overload capacity are low. Because the load torque is proportional to the square of the speed, the load is lighter when running at low speeds (except for Roots blowers). Because this type of load has no special requirements for speed accuracy, so select square torque V/F.

Constant torque load: Most loads have constant torque characteristics, but generally do not require high speed accuracy and dynamic performance. For example, extruders, mixers, conveyor belts, in-plant transportation trams, and translation mechanisms for cranes, etc. Multi-stage V/F operation mode can be selected during model selection.

The controlled object has certain dynamic and static index requirements: this type of load generally requires harder mechanical characteristics at low speeds in order to meet the dynamic and static index requirements of the control system in the production process. SVC control mode can be selected when selecting.

The controlled object has high dynamic and static index requirements: For the occasions where the speed control accuracy and dynamic performance index have high requirements and high-precision synchronous control, VC control mode can be used. For example, elevator, papermaking, plastic film processing production line.

2.8 Selection guide for brake components

(*): Table 2-4 is the guide data, the user can choose different resistance value and power according to the actual situation (but the resistance value must not be less than the recommended value in the table, the power can be large.) The choice of braking resistor needs to be based on actual conditions. The power generated by the motor in the application system is determined, which is related to the inertia of the system, the deceleration time, the energy of the potential energy load, etc., and the customer needs to choose according to the actual situation. The greater the inertia of the system, the shorter the required deceleration time, and the more frequent braking, the greater the power and the smaller the resistance value of the braking resistor should be selected.

2.8.1 Selection of resistance

When braking, almost all the regenerative energy of the motor is consumed in the braking resistor.

According to the formula, $U^2/R=P_b$

- In the formula, U — — — — The braking voltage for stable braking of the system (Different systems are different, generally 700V for 380VAC system)
- P_b — — — — Brake power

2.8.2 Power selection of braking resistor

Theoretically, the power of the braking resistor is the same as the braking power, but considering the derating of 70%.

According to the formula: $0.7 \cdot P_r = P_b \cdot D$

- P_r — — — — Resistance power
- D — — — — Brake frequency (the proportion of the regeneration process in the whole work process)

Elevator — — — — 20% ~30%

Uncoiling and uncoiling — — — — 20% ~30%

Centrifuge ---50%-60%

Incidental braking load ---5%

Generally take 10%

Table 2-7 selection table of inverter brake components

Power	Recommended braking resistor power	Recommended brake resistor resistance	Brake unit	Remarks
0.4KW-T2	80W	$\geq 200\Omega$	Built-in optional	Add "B" after the inverter model
0.7KW-T2	80W	$\geq 150\Omega$		
1.5KW-T2	100W	$\geq 100\Omega$		
2.2KW-T2	100W	$\geq 70\Omega$		
0.7KW-T4	150W	$\geq 300\Omega$	Standard built-in	No special instructions
1.5KW-T4	150W	$\geq 220\Omega$		
2.2KW-T4	250W	$\geq 200\Omega$		
3.7KW-T4	300W	$\geq 130\Omega$		
5.5KW-T4	400W	$\geq 90\Omega$		
7.5KW-T4	500W	$\geq 65\Omega$		
11KW-T4	800W	$\geq 43\Omega$		
15KW-T4	1000W	$\geq 32\Omega$	Built-in optional	Add "B" after the inverter model
18.5KW-T4	1300W	$\geq 25\Omega$		
22KW-T4	1500W	$\geq 22\Omega$		
30KW-T4	2500W	$\geq 16\Omega$	External	VFDBU-35-B
37KW-T4	3.7kW	$\geq 16.0\Omega$		
45KW-T4	4.5kW	$\geq 16\Omega$		
55KW-T4	5.5kW	$\geq 8\Omega$		
75KW-T4	7.5kW	$\geq 8\Omega$		
90KW-T4	4.5kW*2	$\geq 8\Omega \times 2$		
110KW-T4	5.5kW*2	$\geq 8\Omega \times 2$		
132KW-T4	6.5kWx2	$\geq 8\Omega \times 2$		
160KW-T4	16kW	$\geq 2.5\Omega$		
200KW-T4	20kW	$\geq 2.5\Omega$		
220KW-T4	22kW	$\geq 2.5\Omega$		
250KW-T4	12.5kW*2	$\geq 2.5\Omega \times 2$		
280KW-T4	14kW*2	$\geq 2.5\Omega \times 2$		
315KW-T4	16kW*2	$\geq 2.5\Omega \times 2$		
355KW-T4	17kWx2	$\geq 2.5\Omega \times 2$		
400KW-T4	14kWx3	$\geq 2.5\Omega \times 3$		
450KW-T4	15kWx3	$\geq 2.5\Omega \times 3$		

Note: X2 means that two braking units are used in parallel with their respective braking resistors. X3 has the same meaning as X 2.

3

Mechanical and electrical installation

Chapter 3

Chapter 3 Mechanical and Electrical Installation

3.1 Mechanical installation

3.1.1 Installation environment:

- 1) Ambient temperature: The ambient temperature has a great influence on the life of the inverter. The operating environment temperature of the inverter is not allowed to exceed the allowable temperature range (-10°C-50°C) •
- 2) Install the inverter on the surface of a flame-retardant object with enough space around it to dissipate heat. When the inverter is working, it is easy to generate a lot of heat. Install it vertically on the mounting support with screws.
- 3) Please install it in a place that is not easy to vibrate. Vibration should not be greater than 0.6G. Pay special attention to stay away from punching machines and other equipment.
- 4) Avoid installing in a place exposed to direct sunlight, humidity, and water droplets.
- 5) Avoid installing in places with corrosive, flammable, and explosive gases in the air.
- 6) Avoid installing in places with oily, dusty, and metal dust.

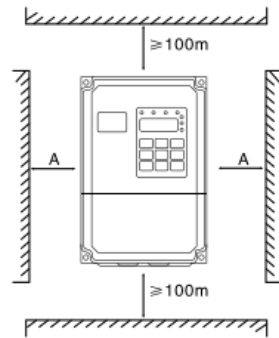

Single unit installation diagram

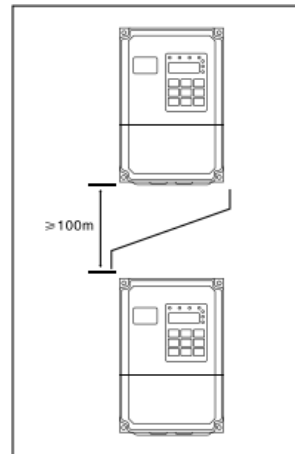

Top and bottom installation diagram

Single installation: when the inverter power is not more than 22kW, the A size can be ignored. When it is more than 22kW, A should be greater than 50mm.

When installing up and down: When installing the inverter up and down, please install the heat-insulating deflector as shown in the figure

Power level	Installation size	
	B	A
≤15KW	≥100mm	No requirement
18.5kW~30kW	≥200mm	≥50mm
≥37KW	≥300mm	≥50mm

Figure 3-1 Schematic diagram of inverter installation

3.1.2 The mechanical installation needs to pay attention to heat dissipation. So please pay attention to the following points:

- 1) Please install the inverter vertically to facilitate the heat dissipation upwards, but not upside down. If there are many inverters in the cabinet, it is best to install them side by side. In the occasions that need to be installed up and down, please refer to the diagram in Figure 3-1 for installation. Install the heat-insulating deflector.
- 2) The installation space is as shown in Figure 3-1 to ensure the heat dissipation space of the inverter. However, please consider the heat dissipation of other components in the cabinet when arranging.
- 3) The mounting bracket must be made of flame-retardant material.
- 4) For applications with metal dust, it is recommended to install the radiator outside the cabinet. At this time, the space inside the fully sealed cabinet should be as large as possible.

3.1.3 Removal and installation of the lower cover

The frequency converter below 15kW adopts a plastic shell. For the removal of the lower cover of the plastic shell, refer to Figure 3-2 and Figure 3-3. Use a tool to push out the hook of the lower cover to the inside.

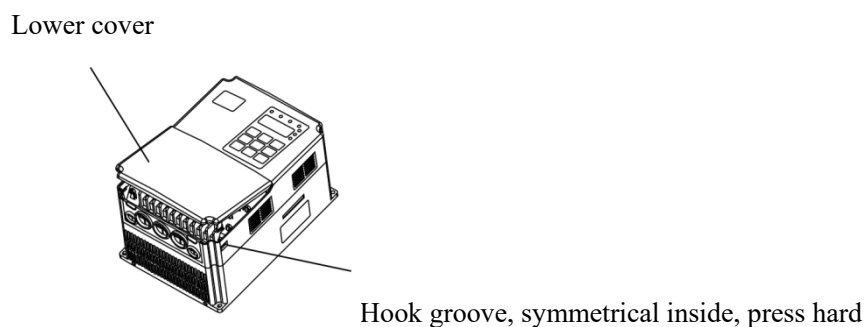



Figure 3-2 Removal of the lower cover of the plastic housing

Inverters above 18.5kW use a sheet metal shell. For the removal of the lower cover of the sheet metal shell, refer to Figure 3-4. Use a tool to directly loosen the screws of the lower cover.

 Danger
When disassembling the lower cover, avoid falling off of the lower cover, which may cause injury to the equipment and people.

Panel

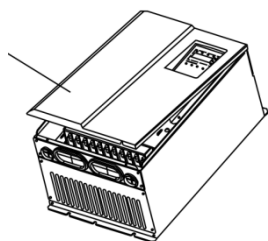

Figure 3-3 Disassembly diagram of the lower cover of the sheet metal shell

3.2 Electrical installation

3.2.1 Selection guide for peripheral electrical components

Table 3-1 Selection Guide for Peripheral Electrical Components of the Inverter

Power	(MCCB) A	Recommended contactor A	Recommended input side main circuit wire mm ²	Recommended output side main circuit wire mm ²	Recommended control loop wire mm ²
H400-0R4G-T2	16	10	2.5	2.5	1.0
H400-0R7G-T2	16	10	2.5	2.5	1.0
H400-1R5G-T2	20	16	4.0	2.5	1.0
H400-2R2G-T2	32	20	6.0	4.0	1.0
H400-0R7G/1R5P-T4	10	10	2.5	2.5	1.0
H400-1R5G/2R2P-T4	16	10	2.5	2.5	1.0
H400-2R2G/4R0P-T4	16	10	2.5	2.5	1.0
H400-4R0G/5R5P-T4	25	16	4.0	4.0	1.0
H400-5R5G/7R5P-T4	32	25	4.0	4.0	1.0
H400-7R5G/11RP-T4	40	32	4.0	4.0	1.0
H400-11RG/15RP-T4	63	40	4.0	4.0	1.0
H400-15RG/18RP-T4	63	40	6.0	6.0	1.0
H400-18RG/22RP-T4	100	63	6	6	1.5
H400-22RG/30RP-T4	100	63	10	10	1.5
H400-30RG/37RP-T4	125	100	16	10	1.5
H400-37RG/45RP-T4	160	100	16	16	1.5
H400-45RG/55RP-T4	200	125	25	25	1.5
H400-55RG/75RP-T4	200	125	35	25	1.5
H400-75RG/90RP-T4	250	160	50	35	1.5
H400-90RG/110RP-T4	250	160	70	35	1.5
H400-110RG/132RP-T4	350	350	120	120	1.5
H400-132RG/160RP-T4	400	400	150	150	1.5
H400-160RG/185RP-T4	500	400	185	185	1.5
H400-185RG/220RP-T4	600	600	150*2	150*2	1.5
H400-220RG/250RP-T4	600	600	150*2	150*2	1.5
H400-250RG/280RP-T4	800	600	185*2	185*2	1.5
H400-280RG/315RP-T4	800	800	185*2	185*2	1.5
H400-315RG/355RP-T4	800	800	150*3	150*3	1.5
H400-355RG/400RP-T4	800	800	150*4	150*4	1.5
H400-400RG/450RP-T4	1000	1000	150*4	150*4	1.5
660V series	See similar current rating of 380V system parameters				

3.2.2 Wiring mode

Three-phase inverter wiring diagram:

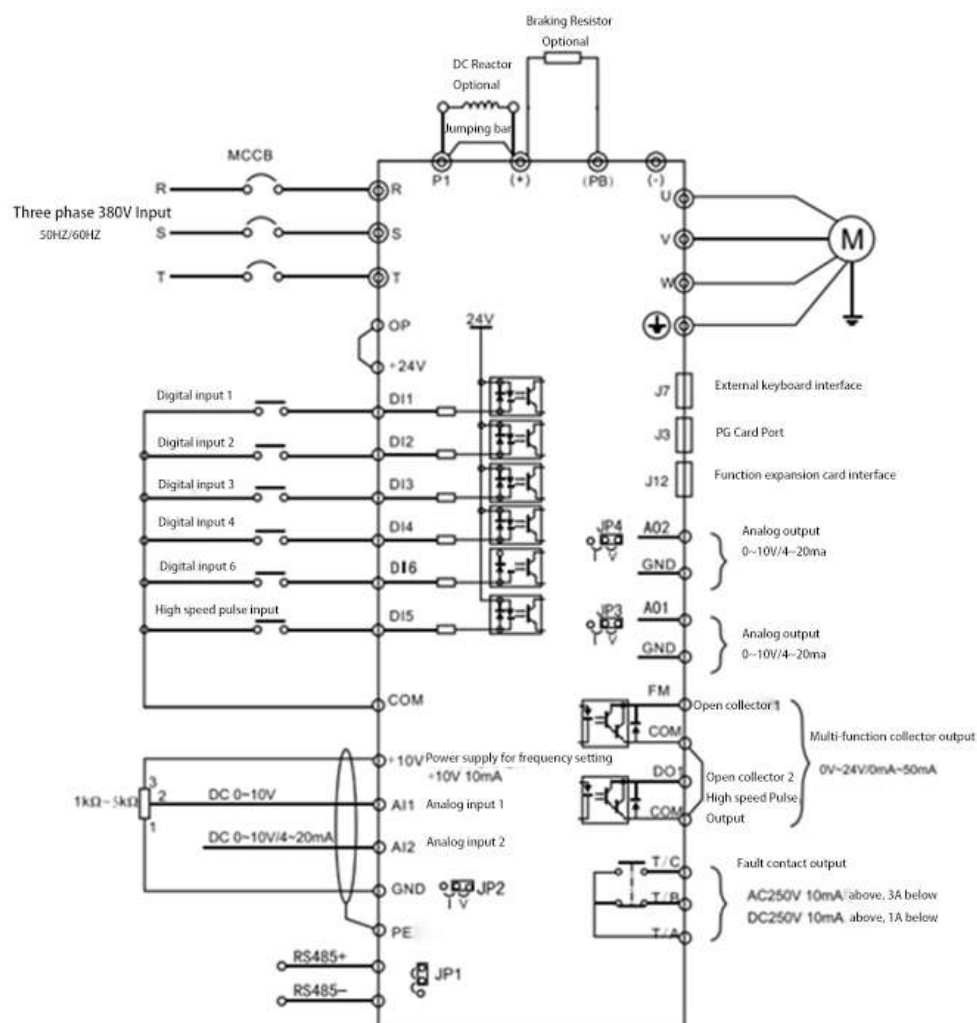

Figure 3-5 Schematic diagram of three-phase inverter wiring

Matters needing attention:

- 1) Terminal ◎ means main circuit terminal. ○ means control circuit terminal.
- 2) 0.75kW-2.2kW built-in braking unit is optional. 3.7kW-15kW built-in braking unit is standard configuration, no need for additional outside installation.
- 3) 7.5kW-55kW built-in DC reactor (optional).
- 4) The brake resistor is selected according to the user's needs, see the brake resistor selection guide for details.

3.2.3 Main circuit terminals and wiring

Danger

1. Confirmed that the power switch is in the OFF state wiring operation can be conducted, or electric shock accidents may occur!
2. Wiring personnel must be professionally trained personnel, otherwise it may cause damage to equipment and personal injury!
3. It must be reliably grounded, otherwise there will be electric shock or fire hazard!

Note

1. Confirm that the input power supply is consistent with the rated value of the inverter, otherwise the inverter will be damaged!
2. Confirm that the motor and the inverter are compatible, otherwise it may damage the motor or cause inverter protection!
3. Do not connect the power supply to the U, V, W terminal, otherwise the inverter will be damaged!
4. Do not connect the braking resistor directly to the DC bus (+), (-), otherwise it may cause a fire!

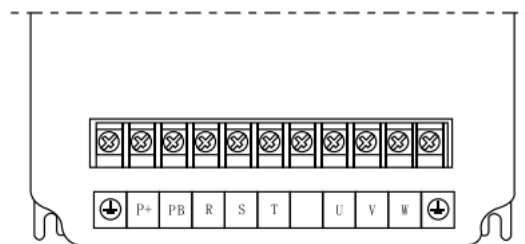

Main circuit wiring terminal diagram 11-15kw

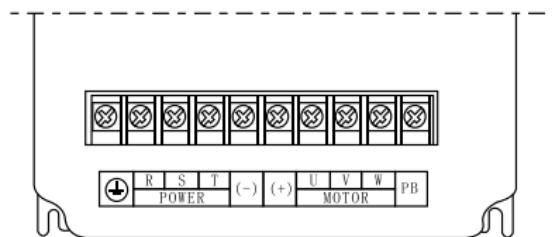

Main circuit wiring terminal diagram 1.5kw~200kw (except 11-15kw)

Figure 3-6 Power terminal diagram of the main circuit of the drive

1) Description of single-phase inverter main circuit terminals:

Terminal mark	Name	Description
L1,L2	Single-phase power input terminal	Single-phase 220V AC power connection point
(+), (-)	DC bus positive and negative terminals	Common DC bus input point
(+), PB	Braking resistor connection terminal	Connect the braking resistor
U,V,W	Inverter output terminal	Connect a three-phase motor
	Ground terminal	Ground terminal

2) Description of three-phase inverter main circuit terminals:

Terminal mark	Name	Description
R,S,T	Three-phase power input terminal	AC input three-phase power connection point
(+), (-)	DC bus positive and negative terminals	Common DC bus input point (connection point of external braking unit above 37kw)
(+), PB	Braking resistor connection terminal	Braking resistor connection point below 30kW
P1, (+)	External reactor connection terminal	External reactor connection point
U,V,W	Inverter output terminal	Connect a three-phase motor
	Ground terminal	Ground terminal

Wiring precautions:

a) Input power L1, L2 or R, S, T:

The input side wiring of the inverter has no phase sequence requirements.

b) DC bus (+) and (-) terminals:

Note that there is residual voltage at the (+) and (-) terminals of the DC bus right after the power failure. You must wait for the CHARGE light to go out and confirm It can be touched after less than 36V, otherwise there is a danger of electric shock.

When using external brake components for those above 37kW, please note that the (+) and (-) polarities cannot be reversed, otherwise the inverter may be damaged or even fire.

The wiring length of the braking unit should not exceed 10m. Twisted-pair wires or tight two-wire parallel wiring should be used. Do not connect the braking resistor directly to the DC bus, which may cause damage to the inverter or even fire.

c) Braking resistor connection terminals (+), PB:

Only models with a built-in braking unit under 30kW, the braking resistor connection terminals are valid. Refer to the recommended value for the selection of braking resistor and the wiring distance should be less than 5m. Otherwise, the inverter may be damaged.

d) External reactor connection terminal P1, (+)

The inverter and reactor of 75kW and above power are installed externally. When assembling, remove the connecting piece between P1 and (+) terminals, and connect the reactor between the two terminals.

e) U, V, W on the output side of the inverter:

Do not connect capacitors or surge absorbers to the output side of the inverter, otherwise it will

cause frequent protection or even damage to the inverter.

When the motor cable is too long, due to the influence of distributed capacitance, electrical resonance is likely to occur, which may cause damage to the motor insulation or produce

Larger leakage current makes the inverter overcurrent protection. When the motor cable length is greater than 100m, an AC output reactor must be installed.

f) Grounding terminal  PE:

The terminal must be grounded reliably, and the resistance of the grounding wire must be less than 0.1Ω. Otherwise, the equipment will work abnormally or even be damaged. Do not share the

grounding terminal  with the neutral N terminal of the power supply.

3.2.4 Control terminals and wiring:

1) The layout diagram of the control circuit terminals is shown below:

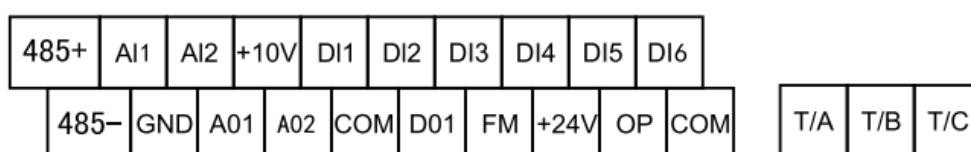

Figure 3-7 Layout of control circuit terminals

2) Function description of control terminal:

Table 3-3

Category	Terminal symbol	Terminal name	Function Description
Power supply	+10V~GND	External +10V power supply	Provide external +10V power supply, maximum output current, 10mA, generally used as an external potentiometer power supply, potentiometer resistance range: 1kΩ -5kΩ
	+24V~COM	External +24V power supply	Provide external +24V power supply, generally used as digital input and output terminal power supply and external sensor power supply, the maximum output current: 200mA
	OP	External power input terminal	The factory default is connected with +24V When using external signals to drive DI1-DI5, OP needs to be connected to the external power supply and disconnected from the +24V power supply terminal
Analog input	AI1~GND	Analog input terminal 1	1. Input voltage range: DC 0V~10V 2. Input impedance: Ω

Analog input	AI2~GND	Analog input terminal 2	<p>1. Input range: DC 0V -10 V /4mA - 20mA, determined by the J8 jumper on the control board</p> <p>2. Input impedance: 22kΩ at voltage input, 500Ω at current input.</p>
Digital input	DI1~COM	Digital input 1	<p>1. Optical coupling isolation, compatible with bipolar input</p> <p>2. Input impedance: 2.4kΩ</p> <p>3. Voltage range when level input: 9V-30V</p>
	DI2~COM	Digital input 2	
	DI3~COM	Digital input 3	
	DI4~COM	Digital input 4	
	DI6~COM	Digital input 6	<p>In addition to the characteristics of DI1-DI4, it can also be used as a high-speed pulse input channel. Maximum input frequency: 50kHz</p>
DI5~COM	High-speed pulse input terminal		
Analog output	A01-GND	Analog output 1	<p>The voltage or current output is determined by the J5 jumper on the control board.</p> <p>Output voltage range: 0V-10V</p> <p>Output current range: 0mA-20mA</p>
Digital output	D01-CME	Digital output 1	<p>Optical coupling isolation, bipolar open-collector output</p> <p>Output voltage range: 0V-24V</p> <p>Output current range: 0mA-50mA</p> <p>Note: The digital output ground CME and the digital input ground COM are internally isolated, but CME and COM have been externally short-circuited when leaving the factory (D01 defaults to +24V drive at this time). When D01 wants to be driven by an external power supply, the external short circuit between CME and COM must be disconnected.</p>
	FM-COM	High-speed pulse output	<p>Restricted by function code P5-00 "FM terminal output mode selection"</p> <p>When used as a high-speed pulse output, the highest frequency is 100KHz;</p> <p>When used as an open collector output, it has the same specifications as D01.</p>
Relay output	T/A -T/B	Normally closed terminal	<p>Contact drive capability: AC250V, 3A. COSØ=0.4. DC30V, 1A</p>
	T/A-T/C	Normally open terminal	
			28-core terminal, interface with optional

Auxiliary interface	J12	Function expansion card interface	cards (I/O expansion card, multi-pump water supply expansion card, tension card, MODBUS communication card, various bus cards and other optional cards)
	J7	External keyboard interface	External keyboard, copy unit interface
Communication Interface	485+ 485-	485 communication	Modbus communication protocol

4

Operation and Display

Chapter 4

Chapter 4 Operation and Display

4.1 Introduction to Operation and Display Interface

The operation panel can be used to modify the function parameters of the inverter, monitor the working status of the inverter and control the operation of the inverter (start and stop). Its appearance and function area are shown in the figure below:

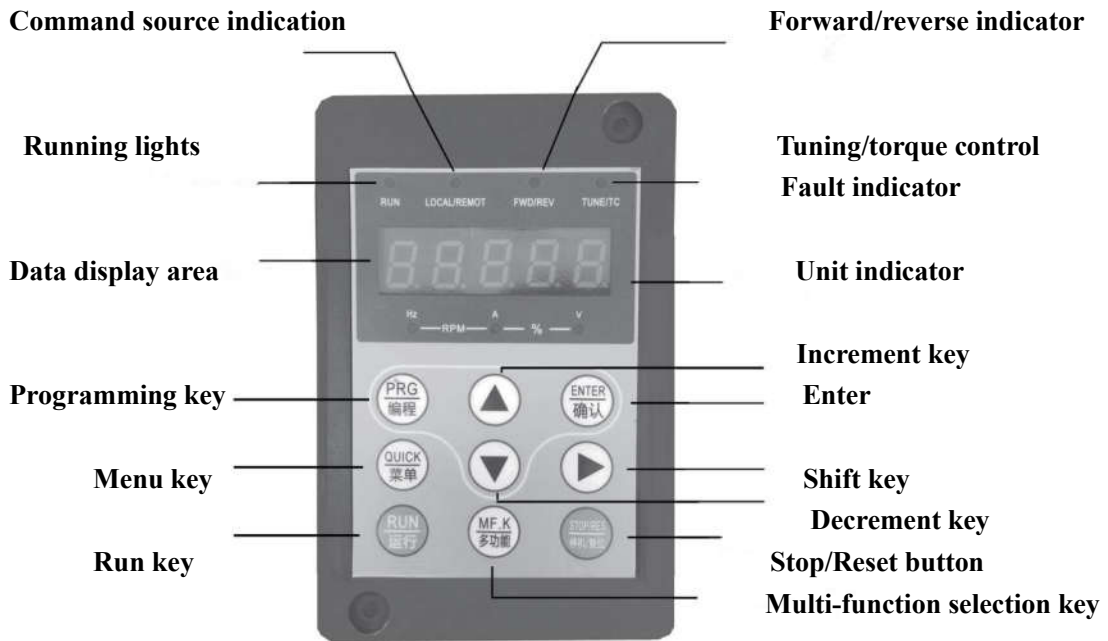

Figure 4-1 Schematic diagram of operation panel without knob



Figure 4-2 Schematic diagram of operation panel with knob

If you need the knob to adjust the speed, you need to set P0-03 to 9

The operation panel with rotary knob can adjust the frequency. Other key functions are the same as the operation panel without rotary knob.

Keyboard button description table

Table 4-1 Keyboard function table

Button	Name	Features
PRG	Programming key	The first level menu Enter or exit
ENTER	Enter	Step by step enter the menu screen, confirm the setting parameters
▲	Increment key	Increment of data or function code
▼	Decrement key	Decrement of data or function code
▶	Shift key	In the stop display interface and the running display interface, the display parameters can be selected cyclically; when modifying the parameters, the modification position of the parameters can be selected
RUN	Run key	In keyboard operation mode, it is used to run operation
STOP/RES	Stop/reset	In the running state, pressing this key can be used to stop the running operation; in the fault alarm state, it can be used to reset the operation. The characteristics of this key are restricted by the function code F7-01.
MF. .K	Multi-function selection key	According to F7-00 for function switching selection
Knob	Incremented or decremented	Increment or decrement data or function code

4.2 Automatic tuning of motor parameters

Select the vector control operation mode. Before the inverter runs, the nameplate parameters of the motor must be accurately input. The inverter nameplate parameters match the standard motor parameters. The vector control mode is strongly dependent on the motor parameters. To obtain good control performance, you must obtain the accurate parameters of the controlled motor.

The steps for automatic tuning of motor parameters are as follows:

First select the command source (P0-02) as the operation panel command channel. Then please input the following parameters according to the actual parameters of the motor:

P1-01: Motor rated power

P1-02: Motor rated voltage

P1-03: Motor rated current

P1-04: Motor rated frequency

P1-05: Motor rated speed

If the motor can be completely disconnected from the load, please select 2 (full tuning) for P1-37. Then press RUN on the keyboard panel Key, the inverter will automatically calculate the following parameters of the motor

P1-06: Stator resistance P1-07: Rotor resistance

P1-08: Leakage inductance P1-09: Mutual inductance

P1-10: No-load excitation current

Complete the automatic tuning of motor parameters.

If the motor cannot be completely disconnected from the load, please select 1 (static tuning) for P1-37. Then press RUN on the keyboard panel key.

The inverter measures the three parameters of stator resistance, rotor resistance and leakage inductance in sequence, and does not measure the mutual inductance and no-load current of the motor.

Users can calculate these two parameters by themselves according to the motor nameplate. The motor nameplate parameters used in the calculation are: rated voltage U, rated current I, rated frequency f and power factor η :

The calculation method of the no-load current of the motor and the calculation method of the mutual inductance of the motor are described in the following formula, where L6 is the leakage inductance of the motor.

$$\text{No-load current } I_0 = I \cdot \sqrt{1 - \eta^2}$$

$$\text{Mutual inductance calculation } L_m = \frac{U}{2\sqrt{3} \pi f I_0} - L_6$$

Where I_0 is the no-load current, L_m is the mutual inductance and L_6 is the leakage inductance

5

Function Parameter Table

Chapter 5

Chapter 5 Function Parameter Table

PP-00 is set to a non-zero value, that is, the parameter protection password is set. In the function parameter mode and the user change parameter mode, the parameter menu can only be entered after the correct password is entered. To cancel the password, you need to set PP-00 to 0.

The parameter menu in the user-defined parameter mode is not protected by a password.

Group P and Group A are the basic function parameters. Group U is the monitoring function parameters.

The symbols in the function table are explained as follows:

- ☆ — modifiable parameter under any condition
- ★ — not modifiable parameter under run status
- — the actual detected parameter, not modifiable
- * — factory parameter, only modifiable for factory, not allowed for users modifying

Brief table of basic function parameters

Function code	Name	Set Range	Factory default	Modification
Group P0 Basic Run Parameters				
P0-00	GP type	1: G type (constant torque load type) 2: P type (fan, water pump load type)	1	★
P0-01	Motor 1 control mode	0: Speed Sensor-less Vector Control (SVC) 1: Vector control with speed sensor (FVC) 2: Voltage/Frequency (V/F) control	2	★
P0-02	Command source selection	0: Operation panel control (LED off) 1: Terminal control (LED on) 2: Communication control (LED flashing)	0	☆
P0-03	Main frequency source X selection	0: Digital setting (preset frequency P0--08. UP/DOWN modifiable, non-retentive at power failure) 1: Digital setting (preset frequency P0--08, UP / DOWN modifiable, retentive at power failure) 2: AI1 3: AI2 4: AI3 (Knob speed adjustment needs to be set to 4) 5: PULSE setting (DI5) 6: Multi-reference 7: Simple PLC setting 8: PID setting 9: Communication setting	4	★
P0-04	Auxiliary frequency source Y selection	The same as P0-03 (main frequency source X selection)	0	★
P0-05	Range of auxiliary frequency Y for X and Y operation	0: Relative to the maximum frequency 1: Relative to frequency source X	0	☆
P0-06	Range of auxiliary frequency Y for X and Y operation	0% ~150%	100%	☆
P0-07	Frequency source superposition selection	One's place: frequency source selection 0: Main frequency source X 1: X and Y operation(operation relationship determined by ten's digit) 2: Switchover between X and Y 3: Switchover between X and 'X and Y operation'	00	☆

		4: Switchover between Y and 'X and Y operation' Ten's place: X and Y operation relationship 0: X+ Y 1: X - Y 2: The maximum of the two 3: The minimum of the two		
P0-08	Preset frequency	0.00Hz ~maximum frequency (P0-10)	50.00Hz	☆
P0-09	Running direction	0: Same direction 1: Reverse direction	0	☆
P0-10	Maximum frequency	50.00Hz ~600.00Hz	50.00Hz	★
P0-11	Source of frequency upper limit	0: Set by P0-12 1: AI1 2: AI2 3: AI3 4: PULSE setting 5: Communication setting	0	★
P0-12	Frequency upper limit	Frequency lower limit (P0-14) to maximum frequency (P0-10)	50.00Hz	☆
P0-13	Frequency upper limit offset	0.00Hz ~maximum frequency P0-10	0.00Hz	☆
P0-14	Frequency lower limit	0.00Hz ~upper limit frequency P0-12	0.00Hz	☆
P0-15	Carrier frequency	0.5kHz ~16.0kHz	Model dependent	☆
P0-16	Carrier frequency adjustment with temperature	0: No 1: yes	1	☆
P0-17	Acceleration time 1	0.00s ~65000s	Model dependent	☆
P0-18	Deceleration time 1	0.00s ~65000s	Model dependent	☆
P0-19	Acceleration/Deceleration time unit	0: 1 second 1: 0.1 seconds 2: 0.01 seconds	1	★
P0-21	Frequency offset of auxiliary frequency source for X and Y operation	0.00Hz ~maximum frequency P01-10	0.00Hz	☆
P0-22	Frequency reference resolution	1: 0.1Hz 2: 0.01Hz	2	★
P0-23	Retentive of digital setting frequency upon power failure	0: Not retentive 1: Retentive	1	☆
P0-24	Motor selection	0: Motor 1 1: Motor 2	0	★
P0-25	Acceleration/Deceleration time base frequency	0: Maximum frequency (P0-10) 1: Set frequency 2: 100Hz	0	★

P0-26	Base frequency for UP/DOWN modification during running	0: Running frequency 1: Set frequency	0	★
P0-27	Binding command source to frequency source	One's place: Binding operation panel command to frequency source 0: No binding 1: Digital setting frequency 2: AI1 3: AI2 4: AI3 5: PULSE setting (D15) 6: Multi-reference 7: Simple PLC 8: PID 9: Communication setting Ten's place: Binding terminal command to frequency source Hundred's digital: Binding operation command to frequency source Thousand's digit: Binding automatically run to frequency source	0000	☆
P0-28	Communication expansion card type	0: Modbus communication card 1: Profi bus-DP communication card 2: CANopen communication card 3: CANlink communication card	0	☆
Group P1 Motor 1 Parameter				
P1-00	Motor type selection	0: Common asynchronous motor 1: Variable frequency asynchronous motor 2: Permanent magnet synchronous motor	0	★
P1-01	Rated motor power	0.1kW~1000.0kW	Model dependent	★
P1-02	Rated motor voltage	1V ~2000V	Model dependent	★
P1-03	Rated motor current	0.01A ~655.35A (Inverter power ≤55kw) 0.1A ~6553.5A (Inverter power >55kW)	Model dependent	★
P1-04	Rated motor frequency	0.01Hz ~Maximum frequency	Model dependent	★
P1-05	Rated motor rotational speed	1rpm ~65535rpm	Model dependent	★
P1-06	Stator resistance (asynchronous motor)	0.001Ω~65.535Ω (AC drive power ≤55kw) 0.0001Ω~6.5535Ω	Tuning parameters	★

		(AC drive power>55kW)		
P1-07	Rotor resistance (asynchronous motor)	0.001Ω~65.535Ω (AC drive power ≤55kW) 0.0001Ω~6.5535Ω (AC drive power>55kW)	Tuning parameters	★
P1-08	leakage inductance reactance (asynchronous motor)	0.01mH ~655.35mH (AC drive power≤55kW) 0.001mH ~65.535mH (AC drive power >55kW)	Tuning parameters	★
P1-09	Mutual inductance reactance (asynchronous motor)	0.01mH ~6553.5mH (AC drive power≤55kW) 0.01mH ~655.35mH (AC drive power >55kW)	Tuning parameters	★
P1-10	No-load current (asynchronous motor)	0.01A ~F1-03 (AC drive power ≤55kW) 0.1A ~F1-03 (AC drive power >55kW)	Tuning parameters	★
P1-16	Stator resistance (synchronous motor)	0.001Ω~65.535Ω (AC drive power ≤55kW) 0.0001Ω~6.5535Ω (AC drive power >55kW)	Tuning parameters	★
P1-17	Shaft D inductance (synchronous motor)	0.01mH ~655.35mH (AC drive power ≤55kW) 0.001mH ~65.535mH (AC drive power >55kW)	Tuning parameters	★
P1-18	Shaft Q inductance (synchronous motor)	0.01mH ~655.35mH (AC drive power ≤55kW) 0.001mH ~65.535mH (AC drive power >55kW)	Tuning parameters	★
P1-20	Back EMF (synchronous Motor)	0.1V ~6553.5V	Tuning parameters	★
P1-27	Encoder pulses per revolution	1 ~65535	1024	★
P1-28	Encoder type	0: ABZ incremental encoder 1: UVW incremental encoder 2: Resolver 3: SIN/COS encoder 4:Wire-saving UVW encoder	0	★
P1-30	A/B phase sequence of ABZ incremental encoder	0: Forward 1: Reverse	0	★
P1-31	Encoder installation angle	0.0 ~359.9°	0.0°	★
P1-32	U,V,W phase sequence of UVW encoder	0: Forward 1: Reverse	0	★
P1-33	UVW encoder angle offset	0.0 ~359.9°	0.0°	★
P1-34	Number of pole pairs of resolver	1~ 65535	1	★
P1-36	PG wire-break fault detection time	0.0s: No action 0.1s ~10.0s	0.0	★

P1-37	Tuning selection	0. No operation 1. Asynchronous motor static tuning 2. Asynchronous motor complete tuning 3. Asynchronous motor fully static self-learning 11: Synchronous machine static tuning 12: Synchronous machine complete tuning	0	★
Group P2 Motor 1 Vector Control Parameter				
P2-00	Speed loop proportional gain 1	1 ~100	30	☆
P2-01	Speed loop integral time 1	0.01s ~10.00s	0.50s	☆
P2-02	Switchover frequency 1	0.00~ P2-05	5.00Hz	☆
P2-03	Speed loop proportional gain 2	1 ~100	20	☆
P2-04	Speed loop integral time 2	0.01s ~10.00s	1.00s	☆
P2-05	Switchover frequency 2	P2-02~Maximum frequency	10.00Hz	☆
P2-06	Vector control slip gain	50%~200%	100%	☆
P2-07	Time constant of speed loop filter	0.000s ~0.100s	0.000s	☆
P2-08	Vector control over-excitation gain	0~200	64	☆
P2-09	Torque upper limit source in speed control mode	0: Function code P2-10 setting 1: AI1 2: AI2 3: AI3 4: PULSE setting 5: Communication setting 6: MIN (AI1, AI2) 7: MAX (AI1, AI2) The full scale of options 1-7 corresponds to P2-10	0	☆
P2-10	Digital setting of torque upper limit in speed control mode	0.0%~200.0%	150.0%	☆
P2-13	Excitation adjustment proportional gain	0~60000	2000	☆
P2-14	Excitation adjustment integral gain	0~60000	1300	☆
P2-15	Torque adjustment proportional gain	0~60000	2000	☆
P2-16	Torque adjustment integral gain	0~60000	1300	☆
P2-17	Speed loop integral property	One's place: integral separation 0: Disabled 1: Enabled	0	☆
P2-18	Synchronous machine field weakening mode	0: Field weakening is invalid 1: Direct calculation mode 2: Automatic adjustment mode	1	☆

P2-19	Synchronous machine field weakening depth	50%~500%	100%	☆
P2-20	Maximum field weakening current	1%~300%	50%	☆
P2-21	Field weakening automatic adjustment gain	10%~500%	100%	☆
P2-22	Field weakening integral multiple	2~10	2	☆
Group P3 V/F Control Parameters				
P3-00	VF curve setting	0. Straight line V/F 1. Multi-point V/F 2. Square V/F 3. 1.2-Power V/F 4. 1.4-Power V/F 6. 1.6-power V/F 8. 1.8-power V/F 9. Reserved 10. VF complete separation mode 11. VF semi-separated mode	0	★
P3-01	Torque boost	0.0%: (Automatic torque boost) 0.1%~30.0%	Model dependent	☆
P3-02	Torque boost cut-off frequency	0.00Hz~Maximum frequency	50.00Hz	★
P3-03	Multi-point VF frequency point 1	0.00Hz ~P3-05	0.00Hz	★
P3-04	Multi-point VF voltage point 1	0.0%~100.0%	0.0%	★
P3-05	Multi-point VF frequency point 2	P3-03~P3-07	0.00Hz	★
P3-06	Multi-point VF voltage point 2	0.0%~100.0%	0.0%	★
P3-07	Multi-point VF frequency point 3	P3-05~Motor rated frequency (P1-04)	0.00Hz	★
P3-08	Multi-point VF voltage point 3	0.0%~100.0%	0.0%	★
P3-09	VF slip compensation gain	0.0%~200.0%	0.0%	☆
P3-10	VF over-excitation gain	0~200	64	☆
P3-11	VF oscillation suppression gain	0~100	Model dependent	☆
P3-13	VF separated voltage source	0. Digital setting (P3-14) 1.AI1 2.AI2 3.AI3 4. PULSE setting (D15) 5. Multi-reference 6. Simple PLC 7.PID 8. Communication setting Note: 100.0% corresponds to the rated motor voltage	0	☆
P3-14	VF separated voltage digital setting	0V ~motor rated voltage	0V	☆

P3-15	Voltage rise time of VF separation	0.0s~1000.0s Note: Indicates the time from 0V to the rated voltage of the motor	0.0s	☆
P3-16	Voltage deceleration time for VF separation	0.0s~1000.0s Note: It indicates the time for the voltage rising from 0V to the rated motor voltage	0.0s	★
P3-17	Stop mode selection upon VF separation	0: Frequency/voltage declining to 0 independently 1: Frequency declining after the voltage declines to 0	0	★
P3-18	Over-current stall action current	50~200%	150%	★
P3-19	Over-current stall inhibition enable	0: Disabled 1: Enabled	0	★
P3-20	Over-current stall suppression gain	0~100	20	★
P3-21	Current compensation coefficient for double-speed over-loss-speed action	50~200%	50%	★
P3-22	Overvoltage stall action voltage	200.0V~2000.0V	Model dependent 220V:380V 380V:760V	★
P3-23	Overvoltage stall enable	0: Disabled 1: Enabled	1	★
P3-24	Over-voltage stall suppression frequency gain.	0~100	30	★
P3-25	Overvoltage stall inhibits voltage gain.	0~100	30	★
P3-26	Overvoltage stall maximum rise frequency limit	0~50HZ	5Hz	★
P3-27	Slip compensation time constant	0.1~10.0S	0.5	★
Group P4 Input Terminal				
P4-00	DI1 terminal function selection	0: No function 1: Forward running (FWD) 2: Reverse operation (REV) 3: Three-line operation control	1	★
P4-01	DI2 terminal function selection	4: Forward jog (FJOG) 5: Reverse Jog (RJOG) 6: Terminal UP 7: Terminal DOWN	4	★
P4-02	DI3 terminal function selection	8: Free parking 9: Fault reset (RESET) 10: Operation pause	9	★

P4-03	DI4 terminal function selection	11: External fault normally open input	12	★
P4-04	DI5 terminal function selection	12: Multi-segment command terminal 1 13: Multi-segment command terminal 2 14: Multi-segment command terminal 3 15: Multi-segment command terminal 4 16: Acceleration and deceleration time selection terminal 1	13	★
P4-05	DI6 terminal function selection	17: Acceleration and deceleration time selection terminal 2 18: Frequency source switching	2	★
P4-06	DI7 terminal function selection	19: UP/DOWN setting clear (terminal, keyboard) 20: Run command switching terminal 21: Prohibition of acceleration and deceleration	0	★
P4-07	DI8 terminal function selection	22: PID pause 23: PLC status reset 24: Swing frequency pause 25: Counter input 26: Counter reset 27: Length count input	0	★
P4-08	DI9 terminal function selection	28: Length reset 29: Torque control prohibited 30: PULSE (pulse) frequency input (Only valid for D15) 31: reserved 32: Immediate DC braking	0	★
P4-09	DI10 terminal function selection	33: External fault normally closed input 34: Frequency modification enable 35: PID action direction is reversed 36: External parking terminal 1 37: Control command switching terminal 2 38: PID integration suspended 39: Frequency source X and preset frequency switch 40: Frequency source Y and preset frequency switch 41: Motor selection terminal 1 42: Motor selection terminal 2 43: PID parameter switch 44: User-defined fault 1 45: User-defined fault 2 46: Speed control/torque control switch	0	★

		47: Emergency stop 48: External parking terminal 2 49: Deceleration DC braking 50: This running time is cleared 51: Two-wire/three-wire switch 52: Reversal is prohibited		
P4-10	DI filter time	0.000s ~ 1.000s	0.010s	☆
P4-11	Terminal command mode	0: Two-wire type 1 1: Two-wire type 2 2: Three-wire type 1 3: Three-line type 2	0	★
P4-12	Terminal UP/DOWN change rate	0.001Hz/s ~ 65.535Hz/s	1.00Hz/s	☆
P4-13	AI curve 1 minimum input	0.00V ~ P4-15	0.00V	☆
P4-14	AI curve 1 minimum input corresponding setting	-100.0% ~ +100.0%	0.0%	☆
P4-15	AI curve 1 maximum input	P4-13 ~ +10.00V	10.00V	☆
P4-16	AI curve 1 maximum input corresponding setting	-100.0% ~ +100.0%	100.0%	☆
P4-17	AI1 filter time	0.00s ~ 10.00s	0.10s	☆
P4-18	AI curve 2 minimum input	0.00V ~ P4-20	0.00V	☆
P4-19	AI curve 2 minimum input corresponding setting	-100.0% ~ +100.0%	0.0%	☆
P4-20	AI curve 2 maximum input	P4-18 ~ +10.00V	10.00V	☆
P4-21	AI curve 2 maximum input corresponding setting	-100.0% ~ +100.0%	100.0%	☆
P4-22	AI2 filter time	0.00S ~ 10.00s	0.10s	☆
P4-23	AI curve 3 minimum input	-10.00V ~ P4-25	0.10V	☆
P4-24	AI curve 3 minimum input corresponding setting	-100.0% ~ +100.0%	0.0%	☆
P4-25	AI curve 3 maximum input	P4-23 ~ +10.00V	9.20V	☆
P4-26	AI curve 3 maximum input corresponding setting	-100.0% ~ +100.0%	100.0%	☆
P4-27	AI3 filter time	0.00s ~ 10.00s	0.10s	☆
P4-28	PULSE minimum input	0.00kHz ~ F4-30	0.00kHz	☆
P4-29	PULSE minimum input corresponding setting	-100.0% ~ 100.0%	0.0%	☆
P4-30	PULSE maximum input	P4-28 ~ 100.00kHz	50.00kHz	☆
P4-31	PULSE maximum input setting	-100.0% ~ 100.0%	100.0%	☆
P4-32	PULSE filter time	0.00s ~ 10.00s	0.10s	☆
P4-33	AI curve selection	One's place: AI1 curve selection 1: Curve 1 (2 points, see P4-13 ~ P4-16) 2: Curve 2 (2 points, see P4-18 ~ P4-21)	321	☆

		3: Curve 3 (2 points, see P4-23 ~ P4-26) 4: Curve 4 (4 points, see A6-00~ A6-07) 5: Curve 5 (4 points, see A6-08~ A6-15) Tens place: AI2 curve selection, same as above Hundreds place: AI3 curve selection, same as above		
P4-34	AI is lower than the minimum input setting selection	One place: AI1 is lower than the minimum input setting selection 0: Corresponding to the minimum input setting 1:0.0% Tens place: AI2 is lower than the minimum input setting selection, same as above Hundreds place: AI3 is lower than the minimum input setting selection, same as above	000	☆
P4-35	D11 delay time	0.0s ~3600.0s	0.0s	★
P4-36	D12 delay time	0.0s ~3600.0s	0.0s	★
P4-37	D13 delay time	0.0s ~3600.0s	0.0s	★
P4-38	D1 terminal effective mode selection 1	0: Active high 1: active low One's place: D11 Ten place: D12 Hundreds place: D13 Thousands: D14 Ten Thousand Places: D15	00000	★
P4-39	D1 terminal effective mode selection 2	0: Active high 1: active low One's place: D16 Ten place: D17 Hundreds place: D18 Thousands: D19 Ten Thousand Places: D110	00000	★
P4-40	AI2 input signal selection	0: Voltage signal 1: Current signal	0	
Group P5 Output Terminal				
P5-00	FM terminal output mode selection	0: Pulse output (FMP) 1: Switch quantity output (FMR)	0	☆
P5-01	FMR output function selection	0: No output	0	☆
P5-02	Control board relay function selection(T/A-T/B-T/C)	1: The inverter is running 2: Fault output (fault shutdown)	2	☆

P5-03	Expansion card relay output function selection (P/A-P/B-P/C)	3: Frequency level detection FDT1 output 4: Frequency reached	0	☆
P5-04	D01 output function selection	5: Running at zero speed (no output when stopped)	1	☆
P5-05	Expansion card D02 output selection	6: Motor overload pre-alarm 7: Inverter overload pre-alarm 8: Set count value reached 9: The designated count value is reached 10: Length reached 11: PLC cycle completed 12: Accumulated running time reached 13: Frequency limitation 14: Torque is being limited 15: Ready to run 16: A11>A12 17: Upper limit frequency reached 18: Lower limit frequency reached (related to operation) 19: Under-voltage status output 20: Communication settings 21: Positioning completed (reserved) 22: Positioning approach (reserved)	4	☆
		23: Zero-speed running 2 (also output when stopping) 24: Accumulated power-on time is reached 25: Frequency level detection FDT2 output 26: Frequency 1 reaches output 27: Frequency 2 reaches output 28: Current 1 reaches the output 29: Current 2 reaches the output 30: Timed arrival output 31: A11 input limit exceeded 32: Dropping 33: Reverse running 34: Zero current state 35: Module temperature reached 36: The output current exceeds the limit 37: Lower limit frequency reached (output at stop) 38: Alarm output (continue to run) 39: Motor over temperature pre-alarm	4	☆

		40: The running time arrives 41: Fault output 42: High pressure output 43: Low pressure output 44: Pressure feedback reaches the set pressure value output		
P5-06	FMP output function selection	0: operating frequency 1. Set frequency 2. Output current 3. Output torque 4. Output power	0	☆
P5-07	A01 output function selection	5. Output voltage 6. PULSE input (100.% corresponds to 100.0kHz) 7, AI1 8, AI2	0	☆
P5-08	Expansion card A02 output function selection	9, AI3 (expansion card) 10, length 11. Count the value 12. Communication settings 13: Motor speed 14: Output current (100.0% corresponds to 1000.0A) 15. Output voltage (100.0% corresponds to 1000.0V) 16, reserved	1	☆
P5-09	FMP output maximum frequency	0.01kHz ~100.00kHz	50.00kHz	☆
P5-10	A01 zero offset coefficient	-100.0% ~ +100.0%	0.0%	☆
P5-11	A01 gain	-1 0.00 ~ +10.00	1.00	☆
P5-12	Extension card A02 zero offset coefficient	-100.0% ~ +100.0%	0.0%	☆
P5-13	Expansion card A02 gain	-10.00 ~ +10.00	1.00	☆
P5-17	FMR output delay time	0.0s ~ 3600.0s	0.0s	☆
P5-18	RELAY1 output delay time	0.0s ~ 3600.0s	0.0s	☆
P5-19	RELAY2 output delay time	0.0s ~ 3600.0s	0.0s	☆
P5-20	DO1 output delay time	0.0s ~ 3600.0s	0.0s	☆
P5-21	DO2 output delay time	0.0s ~ 3600.0s	0.0s	☆
P5-22	DO output terminal effective state selection	0: Positive logic 1: Inverse logic One's place: FMR Ten's place: RELAY 1 Hundreds: RELAY 2 Thousands: D01 Ten Thousand Places: D02	00000	☆

P5-23	AO1 output signal selection	0: Voltage signal 1: Current signal	0	★
Group P6 Start-stop Control				
P6-00	Start method	0: Direct start 1: Speed tracking restart 2: Pre-excitation start (AC asynchronous motor)	0	☆
P6-01	Speed tracking method	0: Start from the stop frequency 1: Start from zero speed 2: Start from the maximum frequency	0	★
P6-02	Speed tracking	1 ~ 100	20	☆
P6-03	Start frequency	0.00Hz ~ 10.00Hz	0.00Hz	☆
P6-04	Start frequency hold time	0.0s-100.0s	0.0s	★
P6-05	Start DC braking current Pre-excitation current	0% ~ 100%	0%	★
P6-06	Start DC braking time / pre-excitation time	0.0s ~ 100.0s	0.0s	★
P6-07	Acceleration and deceleration method	0. linear acceleration and deceleration 1. S-curve acceleration and deceleration A 2. S-curve acceleration and deceleration B	0	★
P6-08	S-Curve segment start time scale	0.0% ~ (100.0% ~P6-09)	30.0%	★
P6-09	Time ratio at the end of S curve	0.0% ~ (100.0% ~P6-08)	30.0%	★
P6-10	Stop mode	0: decelerate to stop 1: Free parking	0	☆
P6-11	Start frequency of DC braking at stop	0.00Hz ~ Maximum frequency	0.00Hz	☆
P6-12	Waiting time for stop DC braking	0.0s ~ 100.0s	0.0s	☆
P6-13	Stop DC braking current	0% ~ 100%	0%	☆
P6-14	Stop DC braking time	0.0s ~ 100.0s	0.0s	☆
P6-15	Brake usage rate	0% ~ 100%	100%	☆
P6-18	Speed tracking current	30% ~ 200%	Model dependent	®
P6-21	Demagnetization time	0.0 ~ 5.0s	Model dependent	®
Group P7 keyboard and Display				
P7-01	MF.K key function selection	0: MF.K is invalid 1: Switch between operation panel command channel and remote command channel (terminal command channel or communication command channel) 2: Forward and reverse switching 3: Forward jog	0	★

		4: reverse inching 5: Panel reversal operation		
P7-02	STOP/RESET key function	0: Only in the keyboard operation mode, the STOP/RES key stop function is valid 1. In any operation mode, the stop function of STOP/RES key is valid	1	☆
P7-03	LED running display parameters 1	0000 ~FFFF Bit00: Operating frequency 1 (Hz) Bit01: Setting frequency (Hz) Bit02: Bus voltage (V) Bit03: Output voltage (V) Bit04: Output current (A) Bit05: Output power (kW) Bit06: Output torque (%) Bit07: D1 input status Bit08: DO output status Bit09: AI1 voltage (V) Bit10: AI2 voltage (V) Bit11: AI3 voltage (V) Bit12: count value Bit13: length value Bit14: Load speed display Bit15: PID setting	401F	☆
P7-04	LED running display parameter 2	0000~FFFF Bit00: PID feedback Bit01: PLC stage Bit02: PULSE input pulse frequency (kHz) Bit03: Running frequency 2 (Hz) Bit04: Remaining running time Bit05: AI1 voltage before calibration (V) Bit06: AI2 voltage before calibration (V) Bit07: AI3 voltage before calibration (V) Bit08: Linear speed Bit09: Current power-on time (Hour) Bit10: Current running time (Min) Bit11: PULSE input pulse frequency (Hz) Bit12: Communication setting value Bit13: Encoder feedback speed (Hz) Bit14: Main frequency X display (Hz) Bit15: Auxiliary frequency Y display (Hz)	0	☆
P7-05	LED stop display parameters	0000~ FFFF	33	☆

		Bit00: Set frequency (Hz) Bit01: Bus voltage (V) Bit02: D1 input status Bit03: DO output status Bit04: A11 voltage (V) Bit05: A12 voltage (V) Bit06: A13 voltage (V) Bit07: Count value Bit08: Length value Bit09: PLC stage Bit10: Load speed Bit11: PID setting Bit12: PULSE input pulse frequency (kHz)		
P7-06	Load speed display coefficient	0.0001~ 6.5000	1.0000	☆
P7-07	Inverter module radiator temperature	0.0°C ~100.0°C	-	●
P7-08	Rectifier bridge radiator temperature	0.0°C ~100.0°C	-	●
P7-09	Cumulative running time	0h ~65535h	-	●
P7-10	product code	400C	-	●
P7-11	Software version number	A100	-	●
P7-12	Load speed display decimal places	0: 0 decimal places 1: 1 decimal place 2: 2 decimal places 3: 3 decimal places	1	☆
P7-13	Accumulated power-on time	0h ~65535h	-	●
P7-14	Cumulative power consumption	0kW ~65535 degrees	-	●
Group P8 Auxiliary Function				
P8-00	Jog operation frequency	0.00Hz ~ Maximum frequency	2.00Hz	☆
P8-01	Jog acceleration time	0.0s ~ 6500.0s	20.0s	☆
P8-02	Jog deceleration time	0.0s ~ 6500.0s	20.0s	☆
P8-03	Acceleration time 2	0.0s ~ 6500.0s	Model dependent	☆
P8-04	Deceleration time 2	0.0s ~ 6500.0s	Model dependent	☆
P8-05	Acceleration time 3	0.0s ~ 6500.0s	Model dependent	☆
P8-06	Deceleration time 3	0.0s ~ 6500.0s	Model	☆

			dependent	
P8-07	Acceleration time 4	0.0s ~ 6500.0s	Model dependent	☆
P8-08	Deceleration time 4	0.0s ~ 6500.0s	Model dependent	☆
P8-09	Hop frequency 1	0.00Hz ~ Maximum frequency	0.00Hz	☆
P8-10	Hop frequency 2	0.00Hz ~ Maximum frequency	0.00Hz	☆
P8-11	Hop frequency amplitude	0.00Hz ~ Maximum frequency	0.01Hz	☆
P8-12	Forward and reverse dead time	0.0s ~ 3000.0s	0.0s	☆
P8-13	Inversion control enable	0: Allow 1: Disable	0	☆
P8-14	The set frequency is lower than the lower limit frequency operation mode	0: Run at lower frequency 1: Stop 2: Zero speed operation	0	☆
P8-15	Droop control	0.00Hz ~ 10.00Hz	0.00Hz	☆
P8-16	Set cumulative power-on arrival time	0h ~ 65000h	0h	☆
P8-17	Set cumulative running arrival time	0h ~ 65000h	0h	☆
P8-18	Start protection selection	0: No protection 1: Protection	1	☆
P8-19	Frequency detection value (FDT1)	0.00Hz ~ Maximum frequency	50.00Hz	☆
P8-20	Frequency detection hysteresis value (FDT1)	0.0% ~ 100.0% (FDT1 level)	5.0%	☆
P8-21	Frequency reach detection width	0.0% ~ 100.0% (Maximum frequency)	0.0%	☆
P8-22	Whether the jumping frequency is valid during acceleration and deceleration	0: invalid 1: valid	0	☆
P8-25	Switching frequency point between acceleration time 1 and acceleration time 2	0.00Hz ~ Maximum frequency	0.00Hz	☆
P8-26	Switching frequency point between deceleration time 1 and deceleration time 2	0.00Hz ~ Maximum frequency	0.00Hz	☆
P8-27	Terminal jog priority	0: invalid 1: valid	0	☆
P8-28	Frequency detection value (FDT2)	0.00Hz ~ Maximum frequency	50.00Hz	☆
P8-29	Frequency detection hysteresis value (FDT2)	0.0% ~ 100.0% (FDT2 level)	5.0%	☆
P8-30	Arbitrary arrival frequency detection value 1	0.00Hz ~ Maximum frequency	50.00Hz	☆
P8-31	Arbitrary arrival frequency detection width 1	0.0% ~ 100.0% (Maximum frequency)	0.0%	☆
P8-32	Arbitrary arrival frequency	0.00Hz ~ Maximum frequency	50.00Hz	☆

	detection value 2			
P8-33	Arbitrary arrival frequency detection width 2	0.0% ~ 100.0% (Maximum frequency)	0.0%	☆
P8-34	Zero current detection level	0.0% ~ 300.0% 100.0% corresponding motor rated current	5.0%	☆
P8-35	Zero current detection delay time	0.01s ~ 600.00s	0.10s	☆
P8-36	The output current exceeds the limit	0.0% (Does not detect) 0.1% ~ 300.0% (Motor rated current)	200.0%	☆
P8-37	Output current overrun detection delay time	0.00s ~ 600s	0.00	☆
P8-38	Arbitrary arrival current 1	0.0% ~ 300.0% (Motor Rated Current)	100.0%	☆
P8-39	Arbitrary arrival current 1 width	0.0% ~ 300.0% (Motor Rated Current)	0.0%	☆
P8-40	Arbitrary arrival current 2	0.0% ~ 300.0% (Motor Rated Current)	100.0%	☆
P8-41	Arbitrary arrival current 2 width	0.0% ~ 300.0% (Motor Rated Current)	0.0%	☆
P8-42	Timing function selection	0: invalid 1: valid	0	☆
P8-43	Timing Running Time Selection	0: P8-44 Setting 1: AI1 2: AI2 3: AI3 Analog input range according to P8-44	0	☆
P8-44	Timing running time	0.0Min~6500.0Min	0.0Min	☆
P8-45	AI1 input voltage protection Lower limit	0.00V~P8-46	3.10V	☆
P8-46	AI1 input voltage protection Upper limit	P8-45~10.00V	6.80V	☆
P8-47	IGBT Module Temperature Arrival	0°C~100°C	75°C	☆
P8-48	Cooling fan control	0: Fan runs only during operation 1: Fan always runs	0	☆
P8-49	Wake up pressure	Sleep Pressure (P8-51)~ Maximum Pressure	2.0KG	☆
P8-50	Wake-up delay time	0.0s~6500.0s	0.0s	☆
P8-51	Sleep pressure	0.0Kg~Wake-up pressure (P8-49)	4.0kg	☆
P8-52	Sleep delay time	0.0s~6500.0s	0.0s	☆
P8-53	Arrival time setting for this run	0.0Min~6500.0Min	0.0Min	☆
P8-54	Output power correction factor	0.00%~200.0%	100%	☆
Group P9 Fault and Protection				
P9-00	Motor overload protection selection	0: Forbid 1: Permit	1	☆
P9-01	Motor overload protection gain	0.20~10.00	1.00	☆
P9-02	Motor overload pre-alarm coefficient	50%~100%	80%	☆

P9-03	Overvoltage stall gain	0~100	0	☆
P9-04	Overvoltage stall protection voltage	120%~150%	130%	☆
P9-05	Overcurrent stall gain	0~100	20	☆
P9-06	Overcurrent stall protection current	100%~200%	150%	☆
P9-07	Power-on-to-ground short-circuit protection options	0: invalid 1: valid	1	☆
P9-08	Starting voltage of braking unit action	200.0~2000.0V	220V: 360V 380V: 690V	☆
P9-09	Fault automatic reset times	0~20	0	☆
P9-10	Action selection for fault D0 during fault automatic reset	0: Non action 1: Action	0	☆
P9-11	Automatic fault reset interval time	0.1s~100.0s	1.0s	☆
P9-12	Input phase loss protection selection	0: Forbid 1: Permit	1	☆
P9-13	Output phase loss protection selection	0: Forbid 1:Permit	1	☆
P9-14	First fault type	0: Non fault 1: Reserve 2: Acceleration Overcurrent 3: Deceleration Overcurrent 4: Constant speed overcurrent 5: Acceleration Overvoltage 6: Deceleration Overvoltage 7: Constant speed overvoltage 8: Snubber resistor overload 9: Under-voltage 10: VFD Overload 11: Motor Overload 12: Input phase loss	-	●
P9-15	Second Fault Type	13: Output phase loss 14: IGBT Module overheat 15: External Fault 16: Communication abnormal 17: Contactor abnormal 18: Overcurrent inspection abnormal 19: Motor tuning abnormal 20: Encoder/PG card abnormal 21: Parameter read and write abnormal 22: VFD hardware abnormal	-	●

		23: Motor-to-Ground Short circuit 24: Reserve 25: Reserve		
P9-16	Third fault type(Latest)	26: Running time arrival 27: User-defined fault 1 28: User-defined fault 2 29: Power-on time arrival 30: Load drop 31: PID feedback loss during running 40: Fast current limit timeout 41: Switch motor when running 42: Speed deviation is too large 43: Motor over-speed 45: Motor overheating 51: Initial position error	-	●
P9-17	Frequency at third fault (Latest)	-	-	●
P9-18	Current value at third fault (Latest)	-	-	●
P9-19	Bus voltage at third fault (Latest)	-	-	●
P9-20	Input terminal status at third fault (Latest)	-	-	●
P9-21	Output terminal status at third fault (Latest)	-	-	●
P9-22	VFD Status at third fault (Latest)	-	-	●
P9-23	Power-on time at third fault(Latest)	-	-	●
P9-24	Running time at third fault (Latest)	-	-	●
P9-27	Frequency at second fault	-	-	●
P9-28	Current value at second fault	-	-	●
P9-29	Bus voltage at second fault	-	-	●
P9-30	Input terminal status at second fault	-	-	●
P9-31	Output terminal status at second fault	-	-	●
P9-32	VFD status at second fault	-	-	●
P9-33	Power-on time at second fault	-	-	●
P9-34	Running time at second fault	-	-	●
P9-37	Frequency at first fault	-	-	●
P9-38	Current value at first fault	-	-	●
P9-39	Bus voltage at first fault	-	-	●
P9-40	Input terminal status at first fault	-	-	●

P9-41	Output terminal status at first fault	-	-	●
P9-42	VFD Status at first fault	-	-	●
P9-43	Power-on time at first fault	-	-	●
P9-44	Running time at fist fault	-	-	●
P9-47	Fault protection action selection 1	<p>Single digit: Motor overload (11)</p> <p>0: Free stop</p> <p>1: Stop according to stop method</p> <p>2: keep on running</p> <p>Ten digit: input phase loss (12)</p> <p>Hundred digit: Output phase loss (13)</p> <p>Thousand Digit: External fault(15)</p> <p>Ten Thousand digit: Communication abnormal (16)</p>	00000	☆
P9-48	Fault protection action selection 2	<p>Single digit: Encoder/PG Card abnormal (20)</p> <p>0: Free stop</p> <p>Ten digit: Function code read & write abnormal (21)</p> <p>0: Free stop</p> <p>1: Stop according to stop method</p> <p>Hundred digit: Reserve</p> <p>Thousand digit: Motor overheating (25)</p> <p>Ten Thousand digit: Running time arrival (26)</p>	00000	☆
P9-49	Fault protection action selection 3	<p>Single digit: User-defined fault 1 (27)</p> <p>0: Free stop</p> <p>1: Stop according to stop method</p> <p>2: Continue running</p> <p>Ten digits: User-defined fault 2 (28)</p> <p>0: Free stop</p> <p>1: Stop according to stop method</p> <p>2: Continue running</p> <p>Hundred digits: power-on time arrival (29)</p> <p>0: Free stop</p> <p>1: Stop according to stop method</p> <p>2: Continue running</p> <p>Thousand digits: Load drop (30)</p> <p>0: Free stop</p> <p>1: Decelerate to stop</p>	00000	☆

		<p>2: Decelerate to 7% of the rated frequency of the motor and then continue to run</p> <p>It will automatically resume running at the set frequency when the load is not dropped</p> <p>Ten thousands digits: PID feedback loss during operation (31)</p> <p>0: Free stop</p> <p>1: Stop according to stop method</p> <p>2: Continue running</p>		
P9-50	Fault protection action selection 4	<p>Single digit: Speed deviation too much (42)</p> <p>0: Free stop</p> <p>1: Stop according to stop method</p> <p>2. Continue running</p> <p>Ten digits: Motor over speed(43)</p> <p>Hundred digits: Initial position error(51)</p>	0000	☆
P9-54	Continue running frequency selection when power is happening	<p>0: running at current frequency</p> <p>1: Running at setting frequency</p> <p>2: Running at the upper limit frequency</p> <p>3: Running at the lower limit frequency</p> <p>4: Abnormal standby frequency operation</p>	0	☆
P9-55	Abnormal standby frequency	60.0%~100.0% (100.0%= Maximum frequency F0-10)	100.0%	☆
P9-56	Motor Temperature sensor type	<p>0: Non-Temperature sensor</p> <p>1: PT100</p> <p>2: PT1000</p>	0`	☆
P9-57	Motor overheating protection threshold	0°C~200°C	110°C	☆
P9-58	Motor overheating pre-alarm threshold	0°C~200°C	90°C	☆
P9-59	Instantaneous power failure action selection	<p>0: Invalid</p> <p>1: Deceleration</p> <p>2: Deceleration stop</p>	0	☆
P9-60	Reserve	F9-62 ~100.0%	100.0%	☆
P9-61	Instantaneous power failure voltage recovery judgment time	0.00s ~100.00s	0.50s	☆
P9-62	Instantaneous power failure action judgment voltage	60.0%~100.0% (Standard Bus Voltage)	80.0%	☆

P9-63	Load drop protection selection	0: invalid 1: valid	0	☆
P9-64	Load drop detection level	0.0 ~100.0%	10.0%	☆
P9-65	Load drop detection time	0.0 ~60.0s	1.0s	☆
P9-66	VFD Overheating pre-alarm value setting	0 ~150°	95°	★
P9-67	Over-speed detection value	0.0% ~50.0% (Maximum frequency)	20.0%	☆
P9-68	Over-speed detection time	0.0s ~60.0s	5.0s	☆
P9-69	Speed deviation too much detection value	0.0%~50.0% (Maximum frequency)	20.0%	☆
P9-70	Speed deviation too much detection time	0.0s ~60.0s	0.0s	☆
P9-71	Instant stop non-stop gain	Kp 0 ~100	40	☆
P9-72	Instant stop non-stop Integral coefficient	Ki 0 ~100	30	☆
P9-73	Instant stop non-stop action deceleration time	0~300.0s	30	☆
Group PA PID Functions				
PA-00	PID Given source	0: PA-01 Given 1: AI1 2:AI2 3:AI3 4: Pulse setting (DI5) 5: Communication given 6: Multi-step command given 7: Up/down setting	7	☆
PA-01	PID value given	0~10.0kg	3.0kg	☆
PA-02	PID feedback source	0:AI1 1:AI2 2:AI3 3:AI1~AI2 4: Pulse setting (DI5) 5: Communication given 6: AI1+AI2 7: MAX (AI1 , AI2) 8: MIN(AI1 , AI2)	0	☆
PA-03	PID Action direction	0: Forward 1: Reverse	0	☆
PA-04	PID Given feedback range	0 ~100.0kg	3.0kg	☆
PA-05	Ratio gain Kp1	0.0 ~100.0	20.0	☆
PA-06	Integration time Ti1	0.01s ~10.00s	2.00s	☆
PA-07	Differential time Td1	0.000s ~10.000s	0.000s	☆
PA-08	PID Reversal cut-off time	0.00 ~ Maximum frequency	2.00Hz	☆
PA-09	PID Deviation limit	0.0% ~100.0%	0.0%	☆

				☆
PA-10	PID Differential limit	0.00% ~100.00%	0.10%	☆
PA-11	PID Given change time	0.00 ~ 650.00s	0.00s	☆
PA-12	PID feedback harmonic filtering time	0.00 ~ 60.00s	0.00s	☆
PA-13	PID Output harmonic filtering time	0.00 ~ 60.00s	0.00s	☆
PA-14	Reserve	-	-	☆
PA-15	Ratio gain Kp2	0.0 ~100.0	20.0	☆
PA-16	Integration time Ti2	0.01s ~10.00s	2.00s	☆
PA-17	Differential time Td2	0.000s ~10.000s	0.000s	☆
PA-18	PID Parameter switch condition	0: Non-switch 1: Switch by DI terminals 2: Automatic switch by deviation	0	☆
PA-19	PID Parameter switch deviation 1	0.0% ~ PA-20	20.0%	☆
PA-20	PID Parameter switch deviation 2	PA-19 ~100.0%	80.0%	☆
PA-21	PID Initial value	0.0% ~100.0%	0.0%	☆
PA-22	PID Initial value keep time	0.00 ~650.00s	0.00s	☆
PA-23	Two output deviation forward maximum value	0.00% ~100.0%	1.00%	☆
PA-24	Two output deviation reverse maximum value	0.00% ~100.0%	1.00%	☆
PA-25	PID Integral property	Single digit: Integral separation 0: Invalid 1: Valid Tens digits: if stop integral when reaching the limit value 0: Continue integral 1: Stop integral	00	☆
PA-26	PID Feedback loss detection value	0.0%: Not charge feedback value loss 0.1% ~100.0%	0.0%	☆
PA-27	PID feedback loss detection time	0.0s ~20.0s	0.0s	☆
PA-28	PID stop calculation	0: Non-calculation when stopping 1: Calculate when stopping	1	☆
PA-29	Wake-up pressure	0 ~ PA.31	2.0kg	★
PA-30	Wake-up delay time	0 ~ 6500.0s	0s	★

PA-31	Sleep pressure	PA.29 ~ PA.04	4	★
PA-32	Sleep delay time	0 ~ 6500.0s	60	★
PA-33	Sleep mode setting	0: Invalid 1: Feedback pressure bigger than the pressure when sleeping 2: Running frequency smaller than output frequency when sleeping 3: Feedback pressure bigger than sleeping pressure and running frequency smaller than sleeping output frequency	0	★
PA-34	Sleep frequency	0 ~ P0.10	30.00Hz	★
PA-35	Pressure proportional linkage enable	0 ~ 1	1	★
PA-36	Wake-up pressure linkage difference value setting	0 ~ PA.01	1.0kg	★
PA-37	Sleep pressure linkage difference value setting	0 ~ PA.01	1.0kg	★
PA-38	High pressure alarm value setting	0 ~ PA.04	0	★
PA-39	Low pressure alarm value setting	0 ~ PA.04	0	★
PA-40	High pressure alarm delay time	0 ~ 6500.0s	0	★
PA-41	Low pressure alarm delay time	0 ~ 6500.0s	0	★
Group Pb Swing frequency, Fixed length and Count				
Pb-00	Swing frequency setting mode	0: Relative to center frequency 1: Relative to maximum frequency	0	☆
Pb-01	Swing frequency amplitude	0.0%~100.0%	0.0%	☆
Pb-02	Sudden jump frequency amplitude	0.0%~50.0%	0.0%	☆
Pb-03	Swing frequency period	0.1s~3000.0s	10.0s	☆
Pb-04	Triangular wave rise time of swing frequency	0.1%~100.0%	50.0%	☆
Pb-05	Setting length	0m~65535m	1000m	☆
Pb-06	Real length	0m~65535m	0m	☆
Pb-07	Pulse number per M	0.1~6553.5	100.0	☆
Pb-08	Setting counting value	1~65535	1000	☆
Pb-09	Appointed counting value	1~65535	1000	☆
Group PC Multi-step Command and Simple PLC				
PC-00	Multi-step command 0	-100.0% ~ 100.0%	0.0%	☆
PC-01	Multi-step command 1	-100.0% ~ 100.0%	0.0%	☆
PC-02	Multi-step command 2	-100.0% ~ 100.0%	0.0%	☆
PC-03	Multi-step command 3	-100.0% ~ 100.0%	0.0%	☆
PC-04	Multi-step command 4	-100.0% ~ 100.0%	0.0%	☆
PC-05	Multi-step command 5	-100.0% ~ 100.0%	0.0%	☆

PC-06	Multi-step command 6	-100.0% ~ 100.0%	0.0%	☆
PC-07	Multi-step command 7	-100.0% ~ 100.0%	0.0%	☆
PC-08	Multi-step command 8	-100.0% ~ 100.0%	0.0%	☆
PC-09	Multi-step command 9	-100.0% ~ 100.0%	0.0%	☆
PC-10	Multi-step command 10	-100.0% ~ 100.0%	0.0%	☆
PC-11	Multi-step command 11	-100.0% ~ 100.0%	0.0%	☆
PC-12	Multi-step command 12	-100.0% ~ 100.0%	0.0%	☆
PC-13	Multi-step command 13	-100.0% ~ 100.0%	0.0%	☆
PC-14	Multi-step command 14	-100.0% ~ 100.0%	0.0%	☆
PC-15	Multi-step command 15	-100.0% ~ 100.0%	0.0%	☆
PC-16	Simple PLC Running mode	0: Shutdown at the end of a single operation 1: Keep the final value at the end of a single run 2: Keep looping	0	☆
PC-17	Simple PLC Power-down memory selection	Single digit: Power-down memory selection 0: Non-memory when powering down 1: Memory when powering down Tens digits: memory selection when stopping 0: non- memory when stopping 1: memory when stopping	00	☆
PC-18	Simple PLC Section 0 running time	0.0s (h)~6553.5s (h)	0.0s (h)	☆
PC-19	Simple PLC Section 0 acceleration & deceleration time selection	0~3	0	☆
PC-20	Simple PLC Section 1 running time	0.0s (h)~6553.5s (h)	0.0s (h)	☆
PC-21	Simple PLC Section 1 acceleration & deceleration time selection	0~3	0	☆
PC-22	Simple PLC Section 2 running time	0.0s (h)~6553.5s (h)	0.0s (h)	☆
PC-23	Simple PLC Section 2 acceleration & deceleration time selection	0~3	0	☆
PC-24	Simple PLC Section 3 running time	0.0s (h)~6553.5s (h)	0.0s (h)	☆
PC-25	Simple PLC Section 3 acceleration & deceleration time selection	0~3	0	☆
PC-26	Simple PLC Section 4 running time	0.0s (h)~6553.5s (h)	0.0s (h)	☆

	time			
PC-27	Simple PLC Section 4 acceleration & deceleration time selection	0~3	0	☆
PC-28	Simple PLC Section 5 running time	0.0s (h)~6553.5s (h)	0.0s (h)	☆
PC-29	Simple PLC Section 5 acceleration & deceleration time selection	0~3	0	☆
PC-30	Simple PLC Section 6 running time	0.0s (h)~6553.5s (h)	0.0s (h)	☆
PC-31	Simple PLC Section 6 acceleration & deceleration time selection	0~3	0	☆
PC-32	Simple PLC Section 7 running time	0.0s (h)~6553.5s (h)	0.0s (h)	☆
PC-33	Simple PLC Section 7 acceleration & deceleration time selection	0~3	0	☆
PC-34	Simple PLC Section 8 running time	0.0s (h)~6553.5s (h)	0.0s (h)	☆
PC-35	Simple PLC Section 8 acceleration & deceleration time selection	0~3	0	☆
PC-36	Simple PLC Section 9 running time	0.0s (h)~6553.5s (h)	0.0s (h)	☆
PC-37	Simple PLC Section 9 acceleration & deceleration time selection	0~3	0	☆
PC-38	Simple PLC Section 10 running time	0.0s (h)~6553.5s (h)	0.0s (h)	☆
PC-39	Simple PLC Section 10 acceleration & deceleration time selection	0~3	0	☆
PC-40	Simple PLC Section 11 running time	0.0s (h)~6553.5s (h)	0.0s (h)	☆
PC-41	Simple PLC Section 11 acceleration & deceleration time selection	0~3	0	☆
PC-42	Simple PLC Section 12 running time	0.0s (h)~6553.5s (h)	0.0s (h)	☆
PC-43	Simple PLC Section 12 acceleration & deceleration time selection	0~3	0	☆

PC-44	Simple PLC Section 13 running time	0.0s (h)~6553.5s (h)	0.0s (h)	☆
PC-45	Simple PLC Section 13 acceleration & deceleration time selection	0~3	0	☆
PC-46	Simple PLC Section 14 running time	0.0s (h)~6553.5s (h)	0.0s (h)	☆
PC-47	Simple PLC Section 14 acceleration & deceleration time selection	0~3	0	☆
PC-48	Simple PLC Section 15 running time	0.0s (h)~6553.5s (h)	0.0s (h)	☆
PC-49	Simple PLC Section 15 acceleration & deceleration time selection	0~3	0	☆
PC-50	Simple PLC running time unit	0: s (second) 1: h (hour)	0	☆
PC-51	Multi-step command 0 given mode	0: Function FC-00 given 1: AI1 2: AI2 3: AI3 4: Pulse 5: PID 6: Pre-set (P0-08) given, UP/DOWN can be modified	0	☆
Group Pd Communication Parameters				
Pd-00	Baud rate	Single digit: MODBUS 0: 300BPS 1: 600BPS 2: 1200BPS 3: 2400BPS 4: 4800BPS 5: 9600BPS 6: 19200BPS 7: 38400BPS 8: 57600BPS 9: 115200BPS Tens digits: Profibus-DP 0: 115200BPS 1: 208300BPS 2: 256000BPS 3: 512000BPS Hundred digits: Reserve Thousand digits: CANlink Baud Rate	6005	☆

		0: 20 1: 50 2: 100 3: 125 4: 250 5: 500 6: 1M		
Pd-01	Data format	0: No parity (8-N-2) 1: Even parity(8-E-1) 2: Odd parity(8-O-1) 3: 8-N-1	0	☆
Pd-02	Local address	1~247, 0 is Broadcast address	1	☆
Pd-03	Response delay	0ms ~20ms	2	☆
Pd-04	Communication timeout time	0.0 (invalid), 0.1s ~ 60.0s	0.0	☆
Pd-05	Data transmission format selection	Single digit: MODBUS 0: Non-standard MODBUS Protocol 1: Standard MODBUS Protocol Tens digits: Profibus-DP 0: PPO1 format 1: PPO2 format 2: PPO3 format 3: PPO5 format	31	☆
Pd-06	Communication reading current resolution	0: 0.01A 1: 0.1A	0	☆
Group PE User-defined Function Code				
PE-00	User function code 0	P0-00 ~ PP-xx A0-00 ~ Ax-xx U0-xx ~ U0-xx	P0.10	☆
PE-01	User function code 1		P0.02	☆
PE-02	User function code 2		P0.03	☆
PE-03	User function code 3		P0.07	☆
PE-04	User function code 4		P0.08	☆
PE-05	User function code 5		P0.17	☆
PE-06	User function code 6		P0.18	☆
PE-07	User function code 7		P3.00	☆
PE-08	User function code 8		P3.01	☆
PE-09	User function code 9		P4.00	☆
PE-10	User function code 10		P4.01	☆
PE-11	User function code 11		P4.02	☆
PE-12	User function code 12		P5.04	☆
PE-13	User function code 13		P5.07	☆
PE-14	User function code 14		P6.00	☆
PE-15	User function code 15		P6.10	☆
PE-16	User function code 16		P0.00	☆
PE-17	User function code 17	P0.00	☆	

PE-18	User function code 18		P0.00	☆
PE-19	User function code 19		P0.00	☆
PE-20	User function code 20		P0.00	☆
PE-21	User function code 21		P0.00	☆
PE-22	User function code 22		P0.00	☆
PE-23	User function code 23		P0.00	☆
PE-24	User function code 24		P0.00	☆
PE-25	User function code 25		P0.00	☆
PE-26	User function code 26		P0.00	☆
PE-27	User function code 27		P0.00	☆
PE-28	User function code 28		P0.00	☆
PE-29	User function code 29		P0.00	☆
Group PP Function Code Management				
PP-00	User password	0~65535	0	☆
PP-01	Parameter initialization	0: Non operation 1: Restore factory parameters, not include motor parameter 2: Clear record information 4: Restore user backup parameter 501: Backup user current parameter	0	★
PP-02	Function parameter group display selection	Single digit: U group display selection 0: non display 1: display Ten digit: A group display selection 0: Non display 1: Display	11	★
P-03	Personalized parameter group display selection	Single digit: Customized user parameter group display selection 0: non display 1: display Ten digits: User modified parameter group display selection 0: non display 1: display	00	☆
PP-04	Function code modification characteristics	0: Can be modified 1: Cannot be modified	0	☆ ☆
PP-05	Added Macro definition menu	0: Invalid 1: Water supply for buildings and communities 2: Water supply for hotels 3: Fire water supply 4: Pressurized water pump 5: Deep water pump	0	☆

		6: Wire drawing parameters of wire drawing machine 7: Winding parameters of wire drawing machine 8: CNC machine function code macro setting		
Group A0 Torque Control Parameter				
A0-00	Speed/Torque control mode selection	0: Speed control 1: Torque control	0	★
A0-01	Torque setting source selection under torque control mode	0: Digital setting 1 (A0-03) 1: AI1 2: AI2 3: AI3 4: Pulse 5: Communication given 6: MIN (AI1, AI2) 7: MAX (AI1, AI2) (full range for 1~7 options, related to A0-03 digital setting)	0	★
A0-03	Torque digital setting under torque control mode	-200.0% ~ 200.0%	150.0%	☆
A0-05	Torque control forward maximum frequency	0.00Hz ~ Maximum frequency	50.00Hz	☆
A0-06	Torque control reverse maximum frequency	0.00Hz ~ Maximum frequency	50.00Hz	☆
A0-07	Torque control acceleration time	0.00s ~ 65000s	0.00s	☆
A0-08	Torque control deceleration time	0.00s ~ 65000s	0.00s	☆
Group A1 Group Virtual IO				
A1-00	Virtual VDI1 terminal function selection	0~59	0	★
A1-01	Virtual VDI2 terminal function selection	0~59	0	★
A1-02	Virtual VDI3 terminal function selection	0~59	0	★
A1-03	Virtual VDI4 terminal function selection	0~59	0	★
A1-04	Virtual VDI5 terminal function selection	0~59	0	★
A1-05	Virtual VDI terminal status setting mode	0: Virtual VDOx status will decide if VDI valid or not 1: Function code A1-06 sets if VDI valid or not Single digit: Virtual VDI1 Tens digits: Virtual VDI2 Hundred digits: VDI3	00000	★

		Thousand digits: VDI4 Ten thousand digits: Virtual VDI5		
A1-06	Virtual VDI terminal status setting	0: Invalid 1: Valid Single digit: Virtual VDI1 Tens digits: Virtual VDI2 Hundred digits: VDI3 Thousand digits: VDI4 Ten thousand digits: Virtual VDI5	00000	★
A1-07	AI1 Terminal for DI Function selection	0~59	0	★
A1-08	AI2 Terminal for DI Function selection	0~59	0	★
A1-09	AI3 Terminal for DI Function selection	0~59	0	★
A1-10	AI Terminal for DI valid mode selection	0: High level valid 1: Low level valid Single digit: AI1 Tens digits: AI2 Hundred digits: AI3	000	★
A1-11	Virtual VD01 output function selection	0: internal short connection with Dix 1~40 : P5 group Physics DO output selection	0	☆
A1-12	Virtual VD02 output function selection	0: internal short connection with Dix 1~40 : P5 group Physics DO output selection	0	☆
A1-13	Virtual VD03 output function selection	0: internal short connection with Dix 1~40 : P5 group Physics DO output selection	0	☆
A1-14	Virtual VD04 output function selection	0: internal short connection with Dix 1~40 : P5 group Physics DO output selection	0	☆
A1-15	Virtual VD05 output function selection	0: internal short connection with Dix 1~40 : P5 group Physics DO output selection	0	☆
A1-16	VDO1 output delay time	0.0s ~ 3600.0s	0.0s	☆
A1-17	VDO2 output delay time	0.0s ~ 3600.0s	0.0s	☆
A1-18	VDO3 output delay time	0.0s ~ 3600.0s	0.0s	☆
A1-19	VDO4 output delay time	0.0s ~ 3600.0s	0.0s	☆
A1-20	VDO5 output delay time	0.0s ~ 3600.0s	0.0s	☆
A1-21	VDO Output terminal valid status selection	0: Positive logic 1: Negative logic Single digit: VDO1 Ten digits: VDO2	00000	☆

		Hundred digits: VDO3 Thousand digits: VDO4 Ten Thousand digits: VDO5		
Group A2 The Second Motor Control				
A2-00	Motor type selection	0: Normal Asynchronous motor 1: Variable-frequency asynchronous motor 2: Permanent magnet synchronous motor	0	★
A2-01	Motor rated power	0.1kw~1000.0kw	Model dependent	★
A2-02	Motor rated voltage	1V~2000V	Model dependent	★
A2-03	Motor rated current	0.01A~655.35A (VFD power ≤55kw) 0.1A~6553.5A (VFD power >55kw)	Model dependent	★
A2-04	Motor rated frequency	0.01Hz~Maximum frequency	Model dependent	★
A2-05	Motor rated speed	1rpm~65535rpm	Model dependent	★
A2-06	Asynchronous motor stator resistor	0.001Ω~65.535Ω (VFD power ≤55kw) 0.0001Ω~6.5535Ω (VFD power >55kw)	Model dependent	★
A2-07	Asynchronous motor rotator resistor	0.001Ω~65.535Ω (VFD power ≤55kw) 0.0001Ω~6.5535Ω (VFD power >55kw)	Model dependent	★
A2-08	Asynchronous motor Leakage inductance	0.01mH~655.35mH (VFD power ≤55kw) 0.001mH~65.535mH (VFD power >55kw)	Model dependent	★
A2-09	Asynchronous motor Mutual inductance	0.01mH~6553.5mH (VFD power ≤55kw) 0.01mH~655.35mH (VFD power >55kw)	Model dependent	★
A2-10	Asynchronous motor empty load current	0.01A~A2-03 (VFD power ≤55kw) 0.1A~A2-03 (VFD power >55kw)	Model dependent	★
A2-16	Synchronous motor stator resistor	0.001Ω~65.535Ω(VFD power ≤55kw) 0.0001Ω~6.5535Ω (VFD power >55kw)	Model dependent	★
A2-17	Synchronous motor D axis inductance	0.01mH~655.35mH (VFD power ≤55kw) 0.001mH~65.535mH (VFD power >55kw)	Model dependent	★

A2-18	Synchronous motor Q axis inductance	0.01mH~655.35mH (VFD power<=55kw) 0.001mH~65.535mH (VFD power >55kw)	Model dependent	★
A2-20	Synchronous motor anti-electromotive force	0.1V~6553.5V	Model dependent	★
A2-27	Encoder line number	1~65535	1024	★
A2-28	Encoder type	0: ABZ Incremental encoder 1: UVW Incremental encoder 2: Resolver transformer 3: Sin-Cos encoder 4: Line-saving UVW encoder	0	★
A2-29	Speed feedback PG selection	0: local PG 1: extended PG 2: Pulse input (DI5)	0	★
A2-30	ABZ incremental encoder AB phase sequence	0: Forward 1: Reverse	0	★
A2-31	Encoder installation angle	0.0~359.9°	0.00°	★
A2-32	UVW incremental encoder UVW sequence	0: Forward 1: Reverse	0	★
A2-33	UVW Encoder Offset angle	0.0~359.9°	0.00°	★
A2-34	Number of pole pairs of resolver transformer	1~65535	1	★
A2-36	Speed feedback PG disconnection inspection time	0.0: No action 0.1s~10.0s	0.0	★
A2-37	Tuning selection	0: No action 1: Asynchronous VFD static tuning 2: Asynchronous VFD full tuning 11: Synchronous Static tuning 12: Synchronous full tuning	0	★
A2-38	Speed loop ratio gain 1	1~100	30	☆
A2-39	Speed loop Integration time 1	0.01s~10.00s	0.50s	☆
A2-40	Switch frequency 1	0.00~A2-43	5.00Hz	☆
A2-41	Speed loop ratio gain 2	1~100	20	☆
A2-42	Speed loop Integration time 2	0.01s~10.00s	1.00s	☆
A2-43	Switch frequency 2	A2-40 ~Maximum frequency	10.00Hz	☆
A2-44	Vector control slip gain	50%~200%	100%	☆
A2-45	Speed ring harmonics filtering time constant	0.000s~0.100s	0.000s	☆
A2-46	Vector control over-excitation gain	0~200	64	☆
A2-47	Torque upper limit source under speed control mode	0: A2-48 setting 1: All	0	☆

		2: AI2 3: AI3 4: Pulse 5: Communication given 6: MIN(AI1, AI2) 7: MAX (AI1, AI2) 1~7 option full range is related to A2-48 digital setting		
A2-48	Torque upper limit setting under speed control mode	0.0%~200.0%	150.0%	☆
A2-51	Excitation adjustment ratio gain	0~20000	2000	☆
A2-52	Excitation adjustment integral gain	0~20000	1300	☆
A2-53	Torque adjustment ratio gain	0~20000	2000	☆
A2-54	Torque adjustment integral gain	0~20000	1300	☆
A2-55	Speed ring integral characteristics	Single digit: integral separation 0: invalid 1: valid	0	☆
A2-56	Synchronous VFD weakening magnetic mode	0: non weakening magnetic 1: direct calculation mode 2: automatic adjusting mode	1	☆
A2-57	Synchronous VFD weakening depth	50%~500%	100%	☆
A2-58	Maximum weakening magnetic current	1%~300%	50%	☆
A2-59	Weakening magnetic automatic adjusting gain	10%~500%	100%	☆
A2-60	Weakening magnetic integral times	2~10	2	☆
A2-61	The second motor control mode	0: Sensor less vector control (SVC) 1: Flux Vector Control (FVC) 2: V/F Control	0	★
A2-62	The second motor acceleration & deceleration time selection	0: same as the first motor 1: Acceleration & deceleration time 1 2: Acceleration & deceleration time 2 3: Acceleration & deceleration time 3 4: Acceleration & deceleration time 4	0	☆ ☆
A2-63	The second motor torque boost	0.0%: Automatic torque boost 0.1%~30%	Model dependent	☆
A2-65	The second oscillation suppression gain	0~100	Model dependent	☆
Group A5 Control Optimization Parameter				
A5-00	DPWM switch upper limit frequency	0.00Hz~15.00Hz	12.00Hz	☆

A5-01	PWM modification Mode	0: Asynchronous modification 1: Synchronous modification	0	☆
A5-02	Dead zone compensation mode selection	0: Non compensation 1: Compensation mode 1 2: Compensation mode 2	1	☆
A5-03	Random PWM depth	0: Random PWM invalid 1~10: PWM carrier frequency random depth	0	☆
A5-04	Quick current limitation enable	0: non enable 1: enable	1	☆
A5-05	Current inspection compensation	0~100	5	☆
A5-06	Under voltage point setting	200.0V~350.0V	350.0V	☆
A5-07	SVC optimization mode selection	0: Non optimization 1: Optimization mode 1 2: Optimization mode 2	1	☆
A5-08	Dead zone time adjustment	100%~200%	150%	☆
A5-09	Overvoltage point setting	200.0V~2200.0V	800.0V	☆
A5-10	Low frequency variable carrier enable	0~1	1	☆
A5-11	Zero speed running output enable	0~1	0	☆
A5-12	Power supply phase loss protection sensitivity	0.0~30.0%	13.0%	☆
A5-13	Over modulation voltage increase percentage	0~110%	103%	☆
A5-14	Software wave-by-wave current limit setting time	100~2500	800	☆
Group A6 AI Curve Setting				
A6-00	AI Curve 4 Minimum input	-10.00V~A6-02	0.00V	☆
A6-01	AI Curve 4 Minimum input relative setting	-100.0% ~ +100.0%	0.0%	☆
A6-02	AI Curve 4 Inflection point 1 input	A6-00 ~ A6-04	3.00V	☆
A6-03	AI Curve 4 Inflection point 1 input relative setting	-100.0% ~ +100.0%	30.0%	☆
A6-04	AI Curve 4 Inflection point 2 input	A6-02~A6-06	6.00V	☆
A6-05	AI Curve 4 Inflection point 2 input relative setting	-100.0% ~ +100.0%	60.0%	☆
A6-06	AI Curve 4 maximum input	A6-06 ~ +10.00V	10.00V	☆
A6-07	AI Curve 4 maximum input relative setting	-100.0% ~ +100.0%	100.0%	☆
A6-08	AI Curve 5 minimum input	-10.00V~A6-10	-10.00V	☆
A6-09	AI Curve 5 minimum input	-100.0% ~ +100.0%	-100.0%	☆

	relative setting			
A6-10	AI Curve 5 Inflection point 1 input	A6-08~A6-12	-3.00V	☆
A6-11	AI Curve 5 Inflection point 1 input relative setting	-100.0% ~ +100.0%	-30.0%	☆
A6-12	AI Curve 5 Inflection point 2 input	A6-10 ~ A6-14	3.00V	☆
A6-13	AI Curve 5 Inflection point 2 input relative setting	-100.0% ~ +100.0%	30.0%	☆
A6-14	AI Curve 5 maximum input	A6-12 ~ +10.00V	10.00V	☆
A6-15	AI Curve 5 maximum input relative setting	-100.0% ~ +100.0%	100.0%	☆
A6-24	AI1 sets Jumping point	-100.0% ~ 100.0%	0.0%	☆
A6-25	AI1 sets jumping amplitude	0.0% ~ 100.0%	0.5%	☆
A6-26	AI2 sets jumping point	-100.0% ~ 100.0%	0.0%	☆
A6-27	AI2 sets jumping amplitude	0.0% ~ 100.0%	0.5%	☆
A6-28	AI3 sets jumping point	-100.0% ~ 100.0%	0.0%	☆
A6-29	AI3 sets jumping amplitude	0.0% ~ 100.0%	0.5%	☆
Group A7 User Programmable Card Parameter				
A7-00	User programmable function selection	0: Invalid 1: valid	0	★
A7-01	Control board output terminal mode selection	0: VFD control 1: User programmable control card control Single digit: FMP(FM terminal as pulse output) Ten digits: Relay (T/A-T/B-T/C) Hundred digits: DO1 Thousand digits: FMR(FM terminal as switch value output) Ten thousand digits: AO1		★
A7-02	Programmable card extended AI3 terminal function configuration			★
A7-03	FMP output	0.0%~100.0%	0.0%	☆
A7-04	AO1 output	0.0%~100.0%	0.0%	☆
A7-05	Switch value output	Binary setting Single digit: FMR Ten digits: Relay 1 Hundred digits: DO	1	☆
A7-06	Programmable card frequency given	0.00%~100.00%	0.0%	☆
A7-07	Programmable card torque given	-200.0%~200.0%	0.0%	☆

A7-08	Programmable card command given	0: no command 1: forward command 2: reverse command 3: forward jog 4: reverse jog 5: free stop 6: deceleration stop 7: fault reset	0	☆
A7-09	Programmable card given fault	0: no fault 80~89: fault code	0	☆
Group AC AI & AO Calibration				
AC-00	AI1 Actual detection voltage 1	0.500V~4.000V	EX-Factory calibration	☆
AC-01	AI1 display voltage 1	0.500V~4.000V	EX-Factory calibration	☆
AC-02	AI1 Actual detection voltage 2	6.000V~9.999V	EX-Factory calibration	☆
AC-03	AI1 display voltage 2	6.000V~9.999V	EX-Factory calibration	☆
AC-04	AI2 Actual detection voltage 1	0.500V~4.000V	EX-Factory calibration	☆
AC-05	AI2 display voltage 1	0.500V~4.000V	EX-Factory calibration	☆
AC-06	AI2 Actual detection voltage 2	6.000V~9.999V	EX-Factory calibration	☆
AC-07	AI2 display voltage 2	6.000V~9.999V	EX-Factory calibration	☆
AC-08	AI3 Actual detection voltage 1	-9.999V~10.000V	EX-Factory calibration	☆
AC-09	AI3 display voltage 1	-9.999V~10.000V	EX-Factory calibration	☆
AC-10	AI3 Actual detection voltage 2	-9.999V~10.000V	EX-Factory calibration	☆
AC-11	AI3 display voltage 2	-9.999V~10.000V	EX-Factory calibration	☆
AC-12	AO1 target voltage 1	0.500V~4.000V	EX-Factory calibration	☆
AC-13	AO1 actual detection voltage 1	0.500V~4.000V	EX-Factory calibration	☆
AC-14	AO1 target voltage 2	6.000V~9.999V	EX-Factory calibration	☆
AC-15	AO1 actual detection voltage 2	6.000V~9.999V	EX-Factory calibration	☆
AC-16	AO2 target voltage 1	0.500V~4.000V	EX-Factory calibration	☆

			calibration	
AC-17	AO2 actual detection voltage 1	0.500V~4.000V	EX-Factory calibration	☆
AC-18	AO2 target voltage 2	6.000V~9.999V	EX-Factory calibration	☆
AC-19	AO2 actual detection voltage 2	6.000V~9.999V	EX-Factory calibration	☆

Summary of monitoring parameters

Function code	Name	Minimum unit
U0 Group Basic monitor parameter		
U0-00	Running frequency(Hz)	0.01Hz
U0-01	Setting frequency (Hz)	0.01Hz
U0-02	Bus voltage(V)	0.1V
U0-03	Output voltage (V)	1V
U0-04	Output current(A)	0.01A
U0-05	Output power (kw)	0.1kw
U0-06	Output torque (%)	0.1%
U0-07	DI input status	1
U0-08	DO output status	1
U0-09	AI1 voltage (V)	0.01V
U0-10	AI2 voltage(V)	0.01V
U0-11	AI3 voltage(V)	0.01V
U0-12	Counting value	1
U0-13	Length value	1
U0-14	Speed display	1
U0-15	PID setting	1
U0-16	PID feedback	1
U0-17	PLC stage	1
U0-18	Pulse input frequency (Hz)	0.01kHz
U0-19	Feedback speed (Unit: 0.1Hz)	0.1Hz
U0-20	Remaining running time	0.1 Min
U0-21	Voltage before AI1 Calibration	0.001V
U0-22	Voltage before AI2Calibration	0.001V
U0-23	Voltage before AI3 Calibration	0.001V
U0-24	Linear speed	1m/Min
U0-25	Current power-on time	1Min
U0-26	Current running time	0.1Min
U0-27	Pulse input frequency	1Hz
U0-28	Communication setting value	0.01%
U0-29	Encoder feedback speed	0.01Hz
U0-30	Main frequency X display	0.01Hz
U0-31	Accessory Y display	0.01Hz
U0-32	Check any RAM address value	1
U0-33	Synchronous VFD rotator address	0.1°
U0-34	Motor temperature value	1°C
U0-35	Target torque (%)	0.1%
U0-36	Resolver position	1
U0-37	Power factor angle	0.1°

U0-38	ABZ address	1
U0-39	VF Separate target voltage	1V
U0-40	VF Separate output voltage	1V
U0-41	DI Visual display of input status	1
U0-42	DO Visual display of input status	1
U0-43	DI Visual display of function status 1 (Function 01-function 40)	1
U0-44	DI Visual display of function status 2 (Function 41-function 80)	1
U0-46	Wake-up pressure	-
U0-47	Sleep pressure	-
U0-48	High pressure alarm value setting	-
U0-49	Low pressure alarm value setting	-
U0-59	Setting frequency (%)	0.01%
U0-60	Running frequency (%)	0.01%
U0-61	VFD status	1
U0-62	Current fault code	1
U0-63	Point-to-point communication delivery value	0.01%
U0-64	Number of slave station	1
U0-65	Torque upper limit	0.01%
U0-66	Communication expansion card	100: CANOpen 200: Profbus-DP 300: CANLink
U0-67	Communication expansion card version no.	Display range

6

Faults and Diagnostics

Chapter 6

Chapter 6 Failure and Diagnosis

6.1 Fault alarm and countermeasures

If a fault occurs during the operation of the inverter system, the inverter will immediately protect the motor and stop output, and at the same time the inverter fault relay contact will act. The inverter panel will display the fault code. The fault type and common solutions corresponding to the fault code are shown in the table below. The list in the table is for reference only. Please do not repair or modify without authorization. If the fault cannot be eliminated, please contact our company or the product agent for technical advice technical support.

Table 6.1 List of fault information

Fault name	Operation panel display	Cause of the malfunction investigation	Troubleshooting countermeasures
Inverter protection unit	Err01	<ol style="list-style-type: none"> 1. Short circuit of inverter output circuit 2. The wiring between the motor and the inverter is too long 3. The module is overheated 4. The internal wiring of the inverter is loose 5. The main control board is abnormal 6. The drive board is abnormal 7. The inverter module is abnormal 	<ol style="list-style-type: none"> 1. Excluding the peripheral fault 2. Install reactor or output filter 3. Check whether the air duct is blocked, whether the fan is working normally, and eliminate the problem 4. Plug in all connecting wires 5. Seek technical support 6. Seek technical support 7. Seek technical support
Accelerating overcurrent	Err02	<ol style="list-style-type: none"> 1. There is a grounding or short circuit in the output circuit of the inverter 2. The control mode is vector and no parameter tuning is performed 3. The acceleration time is too short 4. Manual torque boost or V/F curve is inappropriate 5. The voltage is low 6. Start the rotating motor 7. Sudden increase in load during acceleration 8. The inverter selection is too small 	<ol style="list-style-type: none"> 1. Eliminate peripheral faults 2. Carry out motor parameter tuning 3. Increase acceleration time 4. Adjust manual boost torque or VIF curve 5. Adjust the voltage to normal and stable 6. Select the speed tracking start or wait for the motor to stop before starting 7. Cancel the sudden load 8. Choose a frequency converter with a higher power rating
Deceleration overcurrent	Err03	<ol style="list-style-type: none"> 1. There is a grounding or short circuit in the output circuit of the inverter 2. The control mode is vector and no parameter tuning is performed 3. The deceleration time is too short 	<ol style="list-style-type: none"> 1. Eliminate peripheral faults 2. Carry out motor parameter tuning 3. Increase the deceleration time 4. Adjust the voltage to the normal range 5. Cancel the sudden load

		<ol style="list-style-type: none"> 4. The voltage is low 5. Suddenly increase the load during deceleration 6. There is no additional braking unit and braking resistor 	<ol style="list-style-type: none"> 6. Install braking unit and resistor
Constant speed overcurrent	Err04	<ol style="list-style-type: none"> 1. There is a grounding or short circuit in the output circuit of the inverter 2. The control mode is vector and no parameter tuning is performed 3. The voltage is low 4. Whether there is a sudden load during operation 5. The inverter selection is too small 	<ol style="list-style-type: none"> 1. Eliminate peripheral faults 2. Carry out motor parameter tuning 3. Adjust the voltage to the normal range 4. Cancel the sudden load 5. Choose a frequency converter with a higher power rating
Accelerating overvoltage	Err05	<ol style="list-style-type: none"> 1. The input voltage is too high 2. There is an external force that drives the motor during acceleration 3. The acceleration time is too short 4. There is no additional braking unit and braking resistor 	<ol style="list-style-type: none"> 1. Adjust the voltage to normal range 2. Cancel the external power or install a braking resistor 3. Increase acceleration time 4. Install braking unit and resistor
Deceleration overvoltage	Err06	<ol style="list-style-type: none"> 1. The input voltage is too high 2. There is an external force that drives the motor to run during the deceleration process 3. The deceleration time is too short 4. There is no additional braking unit and braking resistor 	<ol style="list-style-type: none"> 1. Adjust the voltage to the normal range 2. Cancel the external power or install a braking resistor 3. Increase the deceleration time 4. Install braking unit and resistor
Constant speed overvoltage	Err07	<ol style="list-style-type: none"> 1. The input voltage is too high 2. There is an external force that drives the motor to run during operation 	<ol style="list-style-type: none"> 1. Adjust the voltage to the normal range 2. Cancel the external power or install a braking resistor
Control power failure	Err08	<ol style="list-style-type: none"> 1. The input voltage is not within the range specified by the specification 	<ol style="list-style-type: none"> 1. Adjust the voltage to within the range required by the specification
Under voltage fault	Err09	<ol style="list-style-type: none"> 1. Instantaneous power failure 2. The input voltage of the inverter is not within the range required by the specification 3. The bus voltage is abnormal 4. The rectifier bridge and buffer resistance are abnormal 5. The drive board is abnormal 6. Abnormal control board 	<ol style="list-style-type: none"> 1. Reset the fault 2. Adjust the voltage to the normal range 3. Seek technical support 4. Seek technical support 5. Seek technical support 6. Seek technical support
Inverter overload	Err10	<ol style="list-style-type: none"> 1. Whether the load is too large or the motor is blocked 	<ol style="list-style-type: none"> 1. Reduce the load and check the motor and mechanical conditions

		2. The selection of AC frequency converter is too small	2. Choose a frequency converter with a higher power rating
Motor overload	Err11	1. Whether the setting of motor protection parameter P9-01 is appropriate 2. Whether the load is too large or the motor is blocked 3. The inverter selection is too small	1. Set this parameter correctly 2. Reduce the load and check the motor and mechanical conditions 3. Choose a frequency converter with a higher power rating
Input phase loss	Err12	1. The three-phase input power is abnormal 2. The drive board is abnormal 3. The lightning protection board is abnormal 4. The main control board is abnormal	1. Check and eliminate the problems in the peripheral circuit 2. Seek technical support 3. Seek technical support 4. Seek technical support
Output phase loss	Err13	1. The lead from the inverter to the motor is abnormal 2. When the motor is running, the three-phase output of the inverter is not balance 3. The drive board is abnormal 4. The module is abnormal	1. Eliminate peripheral faults 2. Check whether the three-phase winding of the motor is normal and eliminate the fault 3. Seek technical support 4. Seek technical support
Module is overheated	Err14	1. The ambient temperature is too high 2. The air duct is blocked 3. The fan is damaged 4. The module thermistor is damaged 5. The inverter module is damaged	1. Reduce the ambient temperature 2. Clean up the air duct 3. Replace the fan 4. Replace the thermistor 5. Replace the inverter module
External device failure	Err15	1. Input the external fault signal through the multi-function terminal DI 2. Input the external fault signal through the virtual IO function	1. Reset operation 2. Reset operation
Communication fail	Err16	1. The upper computer is not working properly 2. The communication line is abnormal 3. The setting of communication expansion card P0-28 is incorrect 3.The communication parameter PD group is not set correctly	1. Check the upper computer wiring 2. Check the communication cable 3. Correctly set the type of communication expansion card 4. Set the communication parameters correctly
Contact failure	Err17	1. The drive board and power supply are abnormal 2. The contactor is abnormal	1. Replace the drive board or power board 2. Replace the contactor
Current detection failure	Err18	1. Check the abnormality of the Hall device 2. The drive board is abnormal	1. Replace the Hall device 2.Replacing the drive plate
Motor tuning	Err19	1. The motor parameters are not set	1. Set the motor parameters correctly

failure		according to the nameplate 2. Timeout of parameter tuning process	according to the nameplate 2. Check the lead from the inverter to the motor
Code disc failure	Err20	1. The encoder model does not match 2. Encoder connection error 3. The encoder is damaged 4. PG card is abnormal	1. Set the encoder type correctly according to the actual situation 2. Eliminate line faults 3. Replace the encoder 4. Replace PG card
EEPROM read and write failure	Err21	1. The EEPROM chip is damaged	1. Replace the main control board
Inverter hardware failure	Err22	1. There is overpressure 2. There is overcurrent	1. According to the overvoltage fault handling 2. According to the overcurrent fault handling
Short-to-ground fault	Err23	Motor short circuit to ground	Replace cable or motor
Accumulated running time arrival failure	Err26	Accumulated running time reaches the set value	Use parameter initialization function to clear record information
User autonomous operation Fault 1	Err27	1. Input the signal of user-defined fault 1 through the multi-function terminal DI 2. Input the signal of user-defined fault 1 through the virtual IO function	1. Reset operation 2. Reset operation
User-defined fault 2	Err28	1. Input the signal of user-defined fault 2 through the multi-function terminal DI 2. Input the signal of user-defined fault 2 through the virtual IO function	1. Reset operation 2. Reset operation
Accumulated power-on time arrives at fault	Err29	1. The accumulated power-on time reaches the set value	1. Use the parameter initialization function to clear the record information
Offload fault	Err30	1. The inverter operating current is less than P9-64	1. Confirm whether the load is separated or whether the parameter settings of P9-64 and P9-65 conform to the actual operating conditions
PID feedback loss failure during operation	Err31	1. PID feedback is less than the set value of PA-26	1. Check the PID feedback signal or set PA-26 to an appropriate value
Wave-by-wave current	Err40	1. Whether the load is too large or the motor is blocked	1. Reduce the load and check the motor and mechanical conditions

limiting fault		2. The inverter selection is too small	2. Choose a frequency converter with a higher power rating
Switching during operation Motor failure	Err41	Change the current motor selection through the terminal while the inverter is running	Switch the motor after the inverter stops
Speed deviation is too large fault	Err42	1. The encoder parameter setting is incorrect (when PO-01=1) 2. The motor is blocked 3. Excessive speed deviation detection parameters P9-69 and P9-70 settings are unreasonable 4. The wiring between the inverter output terminal UVW and the motor is abnormal	1. Set the encoder parameters correctly 2. Check whether the machine is abnormal, whether the motor is parameterized, whether the torque setting value P2-10 is too small 3. Excessive speed deviation detection parameters P9-69 and P9-70 settings are unreasonable 4. Check whether the wiring between the inverter and the motor is disconnected
Motor over-speed fault	Err43	1. The encoder parameter setting is incorrect 2. No parameter tuning 3. The setting of motor over-speed detection parameters P9-67 and P9-68 is unreasonable	1. Set the encoder parameters correctly 2. Carry out motor parameter tuning 3. Set the detection parameters reasonably according to the actual situation
Motor over temperature fault	Err45	1. The temperature sensor wiring is loose 2. The motor temperature is too high	1. Check the temperature sensor wiring and troubleshoot 2. Reduce the carrier frequency or take other heat dissipation measures to heat the motor
	Err46	High water pressure failure	
	Err47	Low water pressure failure	
Initial position error	Err51	The motor parameters deviate too much from the actual	Reconfirm whether the motor parameters are correct, and focus on whether the rated current is set too small
Master-slave control slave failure	Err55	The slave machine fails, check the slave machine	Troubleshoot according to the slave fault code
Brake pipe protection failure	Err60	The braking resistor is short-circuited or the braking module is abnormal	Check the braking resistor or seek technical support

6.2 Common faults and their solutions

The following faults may be encountered during the use of the inverter. Please refer to the following methods for simple fault analysis:

Table 6-2 Common faults and their solutions

NO.	Failure	Possible Causes	Solution
-----	---------	-----------------	----------

	phenomenon		
1	No display after power-on	<ol style="list-style-type: none"> 1. The grid voltage is not or too low 2. The switching power supply on the drive board of the inverter is faulty 3. The rectifier bridge is damaged 4. The buffer resistance of the inverter is damaged 5. Control board and keyboard failure 6. The connection between the control board and the drive board and keyboard is broken 	<ol style="list-style-type: none"> 1. Check the input power 2. Check the bus voltage 3. Re-plug and re-plug the 32-core cable, and seek service from the manufacturer
2	Power on display Ic	<ol style="list-style-type: none"> 1. The connection between the drive board and the control board is poor 2. The related components on the control board are damaged 3. The motor or motor wire has a short circuit to the ground 4. Hall fault 5. The grid voltage is too low 	<ol style="list-style-type: none"> 1. Re-plug the 32-core cable, and seek service from the manufacturer
3	Power on display "Err23" alarm	<ol style="list-style-type: none"> 1. The motor or output wire is short-circuited to the ground 2. The inverter is damaged 	<ol style="list-style-type: none"> 1. Use a shaker to measure the insulation between the motor and the output wire 2. Seek service from manufacturers
4	When the inverter is powered on, the display is normal, and after running, it displays "Ic" and stops immediately	<ol style="list-style-type: none"> 1. The fan is damaged or blocked 2. The external control terminal wiring short circuit 	<ol style="list-style-type: none"> 1. Replace the fan 2. Eliminate external short circuit faults
5	Frequently report Err14 (module overheating) fault	<ol style="list-style-type: none"> 1. The carrier frequency is set too high 2. The fan is damaged or the air duct is blocked 3. The internal components of the inverter are damaged (thermocouple or other) 	<ol style="list-style-type: none"> 1. Reduce carrier frequency (PO-1S) 2. Replace the fan and clean the air duct 3. Seek service from manufacturers
6	The motor does not rotate after the inverter is running	<ol style="list-style-type: none"> 1. Motor and motor wire 2. Inverter parameter setting error <motor parameter> 3. Poor connection between the drive board and the control board 4. Driver board failure 	<ol style="list-style-type: none"> 1. Reconfirm the connection between the inverter and the motor 2. Replace the motor or clear the mechanical fault 3. Check and reset the motor parameters 4. Seek service from manufacturers
7	DI terminal failure	<ol style="list-style-type: none"> 1. Parameter setting error 2. External signal error 3. The jumper between OP and +24V is 	<ol style="list-style-type: none"> 1. Check and reset the relevant parameters of group P4 2. Reconnect the external signal line

		loose 4. Control board failure	3. Reconfirm the OP and +24V jumper 4. Seek service from manufacturers
8	In closed-loop vector control, the motor speed cannot be increased	1. Encoder failure 2. The encoder is connected to the wrong money or poor contact 3. PG card failure 4. Driver board failure	1. Replace the code plate and reconfirm the wiring 2. Replace PG card 3-4. Seek service from manufacturers
9	The inverter frequently reports over-current and over-voltage faults	1. The motor parameters are set incorrectly 2. The acceleration and deceleration time is inappropriate 3. Load fluctuation	1. Reset the motor parameters or perform motor tuning 2. Set the appropriate acceleration and deceleration time 3. Seek service from manufacturers
10	Power on (or run) report Err17	1. The soft start contactor is not closed	1. Check whether the contactor cable is loose 2. Check whether the contactor is faulty 3. Check whether the 24V power supply of the contactor is faulty 4. Seek service from manufacturers
11	Power on display 8.8.8.8.8	1. The related components on the control board are damaged	1. Replace the control board

7

Protocol

Chapter 7

Chapter 7 Communication Protocol

Appendix 1: Modbus Communication Protocol

The series drive provides the RS232 I RS485 communication interface and supports the Modbus communication protocol. Users can achieve centralized control via computer or PLC, and set the inverter to run command, modify or read function code parameters through the communication protocol.

Read the working status of the inverter and fault information, etc.

1. The protocol

The serial communication protocol defines the information content and usage of the transmitted serial communication. These include: master polling <or broadcast> format; host encoding method, content including: function code, transfer data, and error check, etc. The slave response is also the same structure, including: action confirmation, return data, and error check, etc. If the slave is incorrect, or the request from master can't be handled, it will organize a fault information to the master as a response.

Application method

The frequency converter is connected to the PC/PLC control network with RS232, RS485 bus "single master and multiple slaves".

Bus structure

(1) Interface mode

RS232 / RS485 hardware interface

(2) Transmission mode

The transmission mode is asynchronous serial, half-duplex transmission mode. Only one of the master and slave can only receive data while the master and the slave can only receive data. Data is in the form of packets in the serial asynchronous communication process, one frame transmission.

(3) Topology

This is a single-master multi-slave system. The slave address is 1 ~ 247, 0 is a broadcast communication address. The slave address in the network must be unique.

Protocol description

Series inverter communication protocols are a master of asynchronous serial from M O D b U S communication protocol, only one set in the network.

(Master> Enable protocol (called "query / command)" Other devices <slave> can only make a corresponding action by providing the "query / command" of the data response host or according to the host's "Query / Command". The mater here refers to a personal computer (PC). Industrial Control Device or Programmable Logic Controller (PLC), etc., the slave is the H4000A inverter. The master can communicate with a single slave and also publish broadcast information to all slaves. For the "query/command" sent by master to slave separately,, the slave must return a message (called a

response). For the broadcast information sent by the master, the slave does not need to return a response to the master.

Communication data structure

The Modbus-protocol communication data format of the series inverter is as follows:

Using the RTU mode, the message is sent at least 3.5 character times. Different character times at the network baud rate, which is the most easily implemented <as shown in T1-T2-T3-T4 shown below. The first domain that is transmitted is the device address. The transmission character that can be used is a hexadecimal 0 ... 9, a ... f. Network equipment continuous detection network bus, including pause intervals. When the first domain {address domain} receives, each device is decoded to determine whether to send it to yourself. After the last transmission character, one at least 3.5 the pause of character time is calibrated. A new message will be stopped here.

The entire message frame must be used as a continuous stream transmission. If there is more than 1.5 character times before the frame is completed, the receiving device will refresh the incomplete messages and the next byte is an address domain of a new message. Similarly If a new message begins with the previous message in less than 3.5 characters, the received device will think it is the continuation of the previous message. This will result in an error, because the value of the final CRC is not correct.

RTU Frame Format

Frame head START	3.5 characters time
Slave address ADR	Address: 1 ~ 247
Command code CMD	03: Reading the slave parameters, 06: write the slave parameters
Data content DATA (N-1)	Information content: Function code parameter address, function code parameter number, function code parameter value, etc.
Data content DATA (N-2)	
.....	
Data content DATAO	
CRC CHK high level	Test value: CRC value.
CRC CHK low level	
END	3.5 characters time

CMD (Command order) and **DATA** (Material description)

The order code is 03h. Read N Yu (Word) (up to 12 words), for example: start address F002 of the drive of the slave address 01 continuously read continuous 2

Master command information

ADR	01H
CMD	03H
Start address high level	F0H
Start address low level	02H
Number of registers High	00H
Number of registers	02H
CRC CHK low level	Wait to calculate its CRC CHK value
CRC CHK high level	

Response from slave

PD-05 is set to 0

ADR	01H
CMD	03H
Byte number high level	00H
Byte number low level	04H
Data F002H high level	00H
Data F002H low level	00H
Data F003H high level	00H
Data F003H high	01H
CRC CHK low level	Wait to calculate its CRC CHK value
CRC CHK high level	

PD-05 is set to 1

ADR	01H
CMD	03H
One number of bytes	04H
Data F002H high level	00H
Data F002H low level	00H
Data F003H high level	00H
Data F003H low level	01H
CRC CHK low level	Wait to calculate its CRC CHK value
CRC CHK high level	

Command code: 06H write a word (word) For example: write 5000 (1388H) to the slave address 02H inverter F00 address.

Master command information

ADR	02H
CMD	06H
Data address high level	F0H
Data address low level	0AH
Information content	13H
Low data content	88H
CRC CHK low level	Wait to calculate CRCCHK value
CRC CHK high level	

Response from slave

ADR	02H
CMD	06H
Data address high level	F0H
Data address low level	0AH
Information content	13H
Low data content	88H
CRC CHK low level	Wait to calculate CRCCHK value
CRC CHK high level	

Check mode - CRC check mode: CRC (CYCLICAL Redundancy Check) Using the RTU frame format, the message includes an error detection domain based on a CRC method. The CRC domain detects the content of the entire message. The CRC domain is two bytes, including 16-bit binary value. It is added to the message after the transfer device is calculated. The receiving device recalculates the CRC that receives the message and compares the value in the received CRC domain. If the two CRC values are not equal, the transmission has an error.

The CRC is deposited in 0xffff first, then calls a process to process the 8-bit byte of the clear voice with the value in the current register E only 8bit data in each character, the CRC is valid, start and stop bit, and parity The check digits are invalid.

During the CRC generation, each 8-bit character is different from the register content or (XOR), and the result is moved to the minimum active bit direction, and the maximum effective bit is filled with 0. The LSB is extracted, if the LSB is 1. Register and the value of the preset is different or if the LSB is 0, the whole process is repeated 8 times, after the last bit (<8th bit) is complete, the next 8-bit byte and the current value of the register Different or. The value in the final register is the CRC value after all bytes in the message.

When the CRC is added to a little bit, the low byte is added first, and then high bytes. CRC simple function is as follows:

```

unsigned int crc_chk_value (unsigned char *data_value,unsigned char length) {
    unsigned int crc_value=0xFFFF;
    int i;
    while (length-->0) {
        crc_value^=*data_value++;
        for (i=0;i<8;i++) {
            if (crc_value&0x0001)
                crc_value= (crc_value>>1)
^0xa001;
            else
                crc_value=crc_value>>1;
        }
    }
    return (crc_value) ;
}

```

Address definition of communication parameters

This part is the content of communication, and is used to control the operation of the inverter, the inverter status, and related parameters settings.

Reading and writing function code parameters <Some function code cannot be changed, only for manufacturers or monitoring),

Function Code Parameter Address Number:

Represents rules as parameter addresses with function code group number and label:

High byte: PO-PF (p group), AO-AF (group A>, 70-7F (U group] low byte, OO ~ FF

For example, P3-12, address is expressed as F30C,

Note:

PF group: neither read parameters or parameters;

U Group: You can only read and do not change parameters.

Some parameters cannot be changed when the inverter is in operation, and some parameters are not in the state of the inverter.

Change; Change the function code to the convergence, pay attention to the range, unit, and related instructions of the parameters.

In addition, since the EEPROM is frequently stored, it will reduce the service life of EEPROM. Therefore, some function code is not stored in communication mode, as long as the value in the RAM can be changed.

If it is a P group parameter, to achieve this function, you can implement it as long as the high position F of the function code address is 0.

If it is group A, then we can implement this feature once the high bit A of the function code address is 4.

The corresponding function code address is represented as follows:

High byte: 00-of (p group), 40-4f (group) low byte 00 ~ FF

Such as:

The function code P3-12 is not stored in EEPROM, and the address is represented as 030c.

Function code A0-15 is not stored in EEPROM, the address is expressed as' 4005,

This address represents only written RAM, cannot be called a read action, read, for invalid addresses. For all parameters, you can also use command code 07h to implement this function.

Part parameters of Stop/Run

Parameter Address	Parameter description
1000	Communication setting value (-10000~10000) (Decimal)
1001	Run frequency
1002	Bus voltage
1003	Output voltage
1004	Output current
1005	Output power
1006	Output torque
1007	Run speed
1008	DI input symbol
1009	DO output symbol
100A	AI1 voltage
100B	AI2 voltage
100C	AI3 Voltage
100D	Counting value input
100E	Length value input
100F	Load speed
1010	PID setting
1011	PID feedback
1012	PLC Step
1013	Pulse input frequency, unit: 0.01kHz
1014	Feedback speed, Unit: 0.1Hz
1015	Remaining running time
1016	Voltage before AI1 calibration

1017	Voltage before AI2 calibration
1018	Voltage before AI3 calibration
1019	Linear speed
101A	Current power-on time
101B	Current running time
101C	Pulse input frequency, unit: 1Hz
101D	Communication setting value
101E	Real feedback speed
101F	Main frequency X display
1020	Auxiliary frequency Y display

Notice:

The communication setting value is the percentage of the relative value, 10000 corresponds to 100.00%, -10000 corresponds to -100.00%.

For frequency dimension data, the percentage is relative to the maximum frequency (PO-10). For torque dimension data, the percentage is

It is P2-10, A2-48, A3-48 and A4-48 (the torque upper limit digital setting, corresponding to the first, second, third and fourth motors respectively)

Control command input to the inverter: (write only)

Command word address	Command function
2000	0001: Forward running
	0002: Reverse running
	0003: Forward running jog
	0004: Reverse running jog
	0005: Free stop
	0006: Deceleration stop
	0007: Fault Reset

Read inverter status: (read only)

Status word address	Status word function
3000	0001: Forward running
	0002: Reverse running
	0003: Stop

Parameter selection password verification (if the return is 8888H. means the password verification passed)

Password address	Input password content
1F00	*****

Digital output terminal control: (Read only)

Command address	Command content
2001	BIT0: DO1 output control BIT1: DO2 output control BIT2: RELAY 1 output control BIT3: RELAY 2 output control BIT4: FMR output control BIT5: VDO1 BIT6: VDO2 BIT7: VDO3 BIT8: VDO4 BIT9: VDO5

Analog output AO1 control: (Write only)

Command address	Command content
2002	0~7FFF means 0%~100%

Analog output AO2 control: (Write only)

Command address	Command content
2003	0~7FFF means 0%~100%

Pulse (PULSE) output control: (Write only)

Command address	Command content		
2004	0~7FFF means 0%~100%		

Inverter fault description:

Inverter fault address	Inverter fault information
8000	0000: No fault 0001: reserved 0002: Accelerating overcurrent 0003: Deceleration overcurrent 0004: Constant speed overcurrent 0005: Accelerating overvoltage 0006: Deceleration overvoltage 0007: Constant speed overvoltage 0008: Buffer resistor overload fault 0009: Under-voltage fault OOOA: Inverter overload 0008: Motor overload OOOC: Loss of phase loss 000D: Output phase loss OOOE: module overheated OOOF: External fault 0010: Communication is abnormal 0011: The contactor is abnormal 0012: Current detection failure 0013: Motor tuning failure 0014: Encoder/PG card failure 0015: Parameter read and write exception 0016: Inverter hardware failure 0017: Short-circuit fault of motor to ground 0018: reserved 0019: reserved 001A: The running time arrives 0018: User-defined fault 1 001C: User-defined fault 2 001D: Power-on time arrives 001E: Load drop 001F: PID feedback lost during operation 0028: Fast current limit timeout fault 0029: Switching motor failure during operation 002A: Speed deviation is too large 002B: Motor over-speed 002D: Motor over temperature 005A: Encoder line number setting error 005B: The encoder is not connected 005C: Initial position error 005E: Speed feedback error

Communication Fault information description data (Fault code):

Communication fault address	Fault description
8001	0000: No fault 0001: Incorrect password 0002: Command code error 0003: CRC check code error 0004: invalid address 0005: invalid parameter 0006: Invalid system change 0007: The system is locked 0008: EEPROM operation is in progress

Pd group communication parameter instruction

	Baud rate	Default	6005
Pd-00	Setting range	Single digit: MODBUS Rate 0: 300BPS 1: 600BPS 2: 1200BPS 3: 2400BPS 4: 4800BPS 5: 9600BPS 6: 19200BPS 7: 38400BPS 8: 57600BPS 9: 115200BPS	

This parameter is used to set the data transmission rate between the host computer and the VFD. Note that the baud rate set by the host computer and the VFD must be the same, otherwise, communication cannot be carried out. The baud rate is higher means faster the communication speed is faster.

	Data format	Default	0
Pd-01	Setting range	0: no verification <8,N,2> 1: Even verification <8, E, 1> 2: Odd verification <8, O, 1> 3: no verification <8-N-1>	

Data format of upper computer should be the same as the VFD or it cannot carry out the communication.

	Local address	Default	1
Pd-02	Setting range	1~247, 0 is the broadcast address	

When local address is set to be 0, it is broadcast address which means that it realizes upper computer's broadcast function.

The address of the local machine is unique (except the broadcast address), which is the basis for the point-to-point communication between the host computer and the inverter.

Pd-04	Communication timeout	Default	0.0s
	Setting range	0.0s (Invalid) 0.1~60.0s	

When the function code is set to 0.0s, the communication timeout time parameter is invalid.

When the function code is set to a valid value, if the interval between one communication and the next communication exceeds the communication timeout time, the system will report a communication failure error (Err16). Normally, it is set to invalid. If you set this parameter in a continuous communication system, you can monitor the communication status.

Pd-05	Communication protocol selection	Default	0
	Setting range	0: Non-standard Modbus protocol 1: Standard Modbus protocol	

Pd-05=1: Select standard Modbus protocol

Pd-05=0: When reading the command, the number of bytes returned by the slave is one byte more than that of the standard Modbus protocol. For details, please refer to the "5 Communication Data Structure" section of this protocol.

Pd-05	Communication reading current resolution	Default	0
	Setting range	0: 0.01A 1: 0.1 A	

8

Setting Scheme

Chapter 8

8.1 Constant pressure water supply parameter setting case

The various parameters of constant pressure water supply are as follows. If the user needs to modify, individual parameters can also be modified.

1. P0-02 = 1; terminal control
2. P0-03 = 8; select PID as the main frequency source;
3. P6-10 = 1; free stop,
4. PA-00= 7; When P0-03 is set to 8, press the confirm key, and the set pressure can be modified by the UP/DOWN key
5. PA-01 =3. 0; user set pressure, the default is 3.0, which means 3.0kg pressure,
6. PA-04 = 10.0, pressure gauge range, the default is 10.0kg which means 1MPa, if the user pressure gauge is 1.6MPa, it needs to be set to 16
7. PA-05= 2.0 (Proportional gain)
PA-06= 0.1 (integral gain)

If the pressure fluctuates greatly, proper adjustment of the proportional gain and integral gain can adjust the speed of the pressure change

8. PA-36= 1.0; Difference = set pressure-wake-up pressure;
9. PA-37 = 1.0; Difference = sleep pressure-set pressure
The wake-up pressure can be viewed through U0-46 parameter
The dormant pressure can be checked through U0-47 parameter;
10. Knob control: PA-00 = 3 P7-03 =8001 P7-05 =0803

Display 3 means 3KG pressure, display 4 means 4KG pressure, and so on.

11. If you want to set sleep, please do the following operations:

- PA-28= 1 (calculate during shutdown)
- PA-29 (Wake up pressure)
- PA-30 (Wake-up delay pressure)
- PA-31 (sleep pressure)
- PA-32 (sleep delay time)
- PA-33= 1 (sleep mode).

Machine tool special parameter setting case

If you set PP-05=8, you can call the special parameter group of the machine tool. The parameters are as follows. If the user needs to modify individual parameters, they can also be modified.

1. P0-02 =1; terminal control
2. P0-03 = 2; is selected from All
3. P0-17=1.5; acceleration time
4. P0-18=1.5 Deceleration time
5. P4 -00= 1; forward rotation
6. P4-01= 2; reverse
7. P6-10 = 0; decelerate to stop
8. P6-11=500; start frequency of DC braking at stop
9. P6-13=100; DC braking current at stop
P6-14=2, DC braking time at stop

8.2 Three- Wire operation

1. three- Wire operation:

Example:

P0-02: 1; external terminal control

P4-00: 1; Press the DI1 terminal to run forward, this terminal is a normally open button

P4-01: 2; Press the DI2 terminal to run in reverse, this terminal is a normally open button

P4-02: 3; Three-wire operation control, press DI3 to stop, this terminal needs to be a normally closed switch

P4-11: 2; Three-wire 1

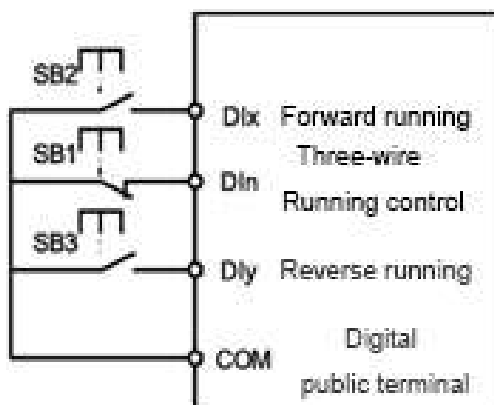

Figure 6-8 three-wire control mode 1

Among them:

SB1: Stop button

SB2: Forward button

SB3: Reverse button

2. Speed display:

If you need the display board to only display the motor speed, set P7-03 to 4000, if the speed is 1500RPM, set P7-06 to 3 ($1500/500=3$);

8.3 Multi-speed operation

Multi-speed setting

P0-02=1; set as terminal control;

P0-03=6; select multi-segment commands;

P4-03=12, P4-04=13; the default DI4 and DI5 are multi-segment command terminals 1 and 2;

The terminal command combination table is as follows:

When the frequency source is selected as multi-speed, 100.0% of the function code PC-00~PC-15 corresponds to the maximum power PC-10.

Attached Table 1 Multi-segment instruction function description

The 4 multi-segment command terminals can be combined into 16 states, which correspond to 16 command setting values. Specific as shown in Table 1:

K4	K3	K2	K1	Command setting	Related parameter
OFF	OFF	OFF	OFF	Multi-step command 0	PC-00
OFF	OFF	OFF	ON	Multi-step command 1	PC-01
OFF	OFF	ON	OFF	Multi-step command 2	PC-02
OFF	OFF	ON	ON	Multi-step command 3	PC-03
OFF	ON	OFF	OFF	Multi-step command 4	PC-04
OFF	ON	OFF	ON	Multi-step command 5	PC-05
OFF	ON	ON	OFF	Multi-step command 6	PC-06
OFF	ON	ON	ON	Multi-step command 7	PC-07
ON	OFF	OFF	OFF	Multi-step command 8	PC-08
ON	OFF	OFF	ON	Multi-step command 9	PC-09
ON	OFF	ON	OFF	Multi-step command 10	PC-10
ON	OFF	ON	ON	Multi-step command 11	PC-11
ON	ON	OFF	OFF	Multi-step command 12	PC-12
ON	ON	OFF	ON	Multi-step command 13	PC-13
ON	ON	ON	OFF	Multi-step command 14	PC-14
ON	ON	ON	ON	Multi-step command 15	PC-15

Example:

Set terminal 1 (D14) to be 30hz when pressed, terminal 2 (D15) to be 40HZ, (terminal is a switch); then the starting segment is PC-00, which can be set to other values, and multiple commands are required according to the combination 0 and multi-segment instruction 1 and multi-segment instruction 3, respectively set PC-00, PC-01, PC-03, the value in 100% corresponds to the percentage of the maximum frequency P0-10, the maximum frequency in this example is 50HZ.

Multi-speed operation:

Example:

P0-02: 1; external terminal operation control

P0-03: 6;

P0-23: 1;

P4-03: 12; D14 terminal is set as multi-segment command terminal 1

P4-04: 13; D15 terminal is set to multi-segment command terminal 2

PC-00: 0; run when D11 is closed 0HZ

PC-01: 60; $(30/\text{maximum frequency } 50\text{HZ}) * 100$; when only D11 and D14 are closed, this is set to 30HZ

PC-02: 80; $(40/\text{maximum frequency } 50\text{HZ}) * 100$; when only D11 and D14 are closed, this is set to 40HZ

Product warranty card

Customer Information	Address:	
	Company name:	Contact:
	Postal code:	contact number:
Product information	Model:	
	Barcode (pasted here)	
	Agency Name:	
Fault information	(Maintenance time and content):	
	Maintenance person:	

Warranty Agreement

1. The warranty period of this product is 18 months (subject to the barcode information of the fuselage). During the warranty period, if the product is sold out of order or damaged under normal use according to the user manual, our company is responsible for free maintenance.
2. During the warranty period, a certain repair fee will be charged for damage caused by the following reasons:
 - A. Damage to the machine caused by mistakes in use and unauthorized repair and transformation:
 - B. Machine damage caused by fire, flood, abnormal voltage, other natural disasters and secondary disasters:
 - C. Hardware damage caused by artificial drop and transportation after purchase;
 - D. Damage to the machine caused by operation not in accordance with the user manual provided by our company:
 - E. Failure and damage caused by obstacles other than the machine (such as external equipment factors):
3. When the product fails or is damaged, please fill in the contents of the "Product Warranty Card" correctly and in detail.
4. The maintenance fee shall be collected in accordance with the "Maintenance Price List" newly adjusted by our company.
5. This warranty card will not be reissued under normal circumstances. You must keep this card and show it to the maintenance personnel during the warranty period.
6. If you have any questions during the service, please contact our agent or our company in time.
7. The right to interpret this agreement belongs to the company.



AC Drive/VFD/Frequency Inverter, Solar Pump Inverter, Soft Starter, HMI&PLC ALL-IN-ONE Device